



Spring 2020 - CIV E495

James Haughey

San Diego State University

5/6/2020

***100% Civil Creations Inc. Design Submittal for: Coronado
NAB Pedestrian Tunnel***

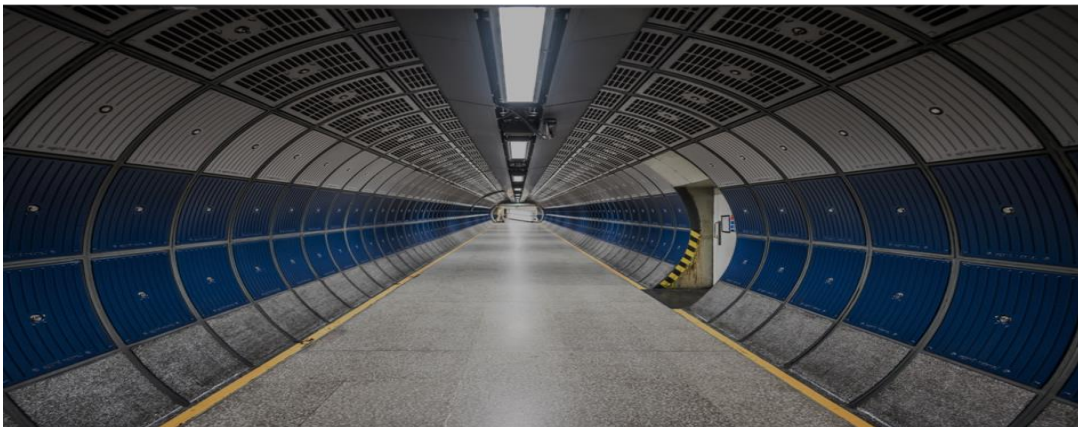

Prepared for: City of Coronado

Prepared by: Civil Creations Inc.



San Diego, CA

Civil Creations Inc. Team 22

Project Manager: Mina Ghareeb

Aya Alaboosi, Lara Al Issa, Ayat Alobaidi

Hani Noori, Mustafa Rasheed

Table of Contents

1. Executive Summary	1
1.1 Vicinity Map	3
2. Project Background, Need and Purpose.....	3
2.1 Scope of Work	3
2.2 Project Background	4
2.3 Existing Site Conditions	4
3. Basis of Design	5
4. References	6
5. List of Appendices	
Appendix 1: Geotechnical Study.....	8
Appendix 2: Storm Water Study.....	24
Appendix 3: Traffic Control Study... ..	34
Appendix 4: Structural Design	47
Appendix 5: Construction Management	69
6. Cost Estimate	100
7. Project Schedule	101
8. Construction Schedule	102
9. Plans Set	103

1. Executive Summary

Naval Base Coronado is located at Coronado, California. It's one of the most unique and beautiful beachfront cities in the world. By measuring only 13.5 square miles and located just minutes from downtown Dan Diego. This enchanted island has it all: beaches, parks, numerous recreational activities, highly rated schools, top notch municipal services, a wonderful climate and an ideal location. The Naval Amphibious Base (NAB), Coronado was established in 1943. NAB is the home to over 30 tenant commands with a population of approximately 5,000 personnel, including major commands. In the present state, the City of Coronado has decided to build a pedestrian tunnel connecting NAB East Gate and the West Gate. The current pedestrian crossing at Caltrans SR-75 and Tarawa Road is coordinated with automobile traffic and presents a safety hazard for pedestrians. The City of Coronado would therefore like to replace the current at-grade foot crossing with a secure, pedestrian-friendly tunnel under SR-75. The purpose of a pedestrian tunnel is to improve safety, accessibility, and faster connectivity.

Naval Amphibious Base Coronado (NAB Coronado) is a naval installation located in Coronado, California. The base, situated on the Silver Strand, between San Diego Bay and the Pacific Ocean, is a major Navy shore command, supporting over 30 tenant commands, and is the West Coast focal point for special and expeditionary warfare training and operations. The on-base population is 5,000 military personnel and 7,000 students and reservists. The base is one of the eight components of Naval Base Coronado (NBC). The City of Coronado has decided that it is the time to replace the existing at-grade pedestrian crossing with a safe pedestrian-friendly tunnel under SR-75 to connect between the two gates due to a significant safety hazard for pedestrians between Caltrans SR-75 at the existing traffic signal at Tarawa Road. This existing pedestrian crossing is synchronized with vehicular crossing traffic.

The principal outcomes of this project are to assure safety for the pedestrians by presenting value-oriented, client-focused services equipped with a clear understanding of laws, codes and current practices. Our goal is client satisfaction achieved by ensuring



that we understand the Clients' needs, wants, and concerns while providing work that is accurate, complete on schedule and within budget. It also provides all the labor and materials required to carry out assessments and construction services including civil, site, structural, geotechnical and communications work for existing tunnel to support the facilities project.

The team looks out for the interests of the owner. Civil Creations Inc. uses a competition in the selection of the trades to improve the efficiency and quality for owner. Taking into consideration, there are possibilities of risks that will occur in the future, Civil Creations Inc. has done well in considering such risks. For mobilization and access, the workers have considered the layout of where the materials are placed and rerouting the paths the machinery will be operated on site. For equipment and material delay due to COVID-19, Civil Creations Inc. has considered the types of equipment will be used for this project along with the use of two trucks haul for both sides to increase efficiency and production operation. To ensure the accuracy of schedule and to finish on time, the team will conduct a weekly meeting with all trades and will send a schedule monthly updates to the owner to ensure that everyone on track with the baseline schedule and can pre-plan any activities or deliveries.

The goal for the Civil Creations Inc. is working proficiency, and accurately by designing and working with the City of Coronado to approach the needs for this project Coronado NAB Pedestrian Tunnel. Safety for the pedestrian is our priority; this project is to assure safety and accessibility to pedestrian. As a result, the bus stop will be temporary relocated to Rendova Road. A Boring Machine (TBM) that weight 30 tons will be used after the excavation of 22 ft. Due to the Global issue for what is happening and it is a hardly effecting the global economic and the US specific, the Civil Creations INC trying to make the total cost estimate because of COVID-19, the total cost estimate for this project is \$3,138,390.00 This is considered a competitive. The commencement date for this project is 6th of July 2020 and the competition date is 16th of January 2023.

1.1 Vicinity Map



Figure 1: Vicinity Map

2. Project Background, Need and Purpose

2.1 Scope of Work

This project is in replacement of the pedestrian cross Caltrans SR-75 at the existing traffic signal at Tarawa Road with the existing at-grade pedestrian crossing with a safe pedestrian-friendly tunnel under SR-75. This pedestrian tunnel is to connect both sides of NAB under CaltransSR-75 to assure safety for the pedestrians

To fulfil City of Coronado, Civil Creations Inc. will perform the following work:

1. Provide site survey and inspection of existing
2. Design engineering documents and provide construction drawings
3. Structural design of the tunnel
4. Provide Civil site designs
5. Provide Geotechnical studies with the type of soil with recommendations
6. Storm water studies

7. Providing a detail Cost estimate
8. Provide traffic control studies

2.2 Project Background

Naval Amphibious Base Coronado (NAB Coronado) is a naval installation located in Coronado, California. The base, situated on the Silver Strand, between San Diego Bay and the Pacific Ocean, is a major Navy shore command, supporting over 30 tenant commands, and is the West Coast focal point for special and expeditionary warfare training and operations. The on-base population is 5,000 military personnel and 7,000 students and reservists. The base is one of the eight components of Naval Base Coronado (NBC). The City of Coronado has decided that it is the time to replace the existing at-grade pedestrian crossing with a safe pedestrian-friendly tunnel under SR-75 to connect between the two gates due to a significant safety hazard for pedestrians between Caltrans SR-75 at the existing traffic signal at Tarawa Road. This existing pedestrian crossing is synchronized with vehicular crossing traffic.

2.3 Existing Site Conditions

On the day of the visit, there was sewer drainage by the traffic light next to the east gate of the NAB. On the east side of SR 75, some trees and bushes will need to be removed in order to build the access ramp and stairs.

Silver Strand Boulevard is the only major corridor adjacent to NAB that military personnel can use to leave the facility to access the cities of Coronado and Imperial Beach and other major arterials and freeways. MTS Route 901 is the only bus route that provides transit service to and from NAB. This route has a bus stop outside of Gate 7 along Silver Strand Boulevard and needs to be relocated for construction activities. The proposed tunnel location will connect the east and west side of Tarawa Rd as it will be explained later in the report.

3. Basis of Design

This Pedestrian Tunnel to be 10 ft deep and 20 ft width walkway. The 20 ft consists of 10 feet of 5 feet upstairs, 5 ft downstairs, and 10 feet for disabled people. We are assuming that there should be a removal of existing sidewalk, existing concrete, existing trees. This tunnel should have access for pedestrians and people with disabilities. That means, ADA requirements should be adhered to, and further honed to make access leisurely and amenable to all involved. The TBM boring machine will be used for the boring process. The core structure will be steel and reinforced concrete to maintain more than enough strength for pedestrian use. Allowances for maintenance access, and public safety barriers will be made.

Civil Creations Inc. will prepare for the City of Coronado, Caltrans, Navy, State, and Federal Permits, the Structural design of the new tunnel, and providing detailed Cost Estimation at Submittal, which is discussed in the report.

Furthermore, our assumed tunnel will allow the pedestrian to traverse without waiting for a whole pedestrian cycle of traffic light. Another advantage of the road tunnel system is that its use will lead to a sharp decrease in the time spent in a motor vehicle, resulting in a reduction in traffic congestion.

4. List of References

Climate Coronado - California. (2020). Retrieved March 5, 2020

"Industrial Gantry Crane for Tunnel, Subway, & Metro Use." Dongqi Crane, 22 Nov. 2011

Ninyo & Moore, 2008, Proposal for Geotechnical Design Evaluation, Planned Boat House Club room, Glorietta Bay Park, Coronado, California, dated November 26

"Roadheaders for Tunneling, Excavation, and More." Antraquip Corporation | Roadheaders & Hydraulic Cutters | Rock Grinders, Concrete Cutters, 2020

Sinoart. "Gantry Crane for Tunnel Boring Machine." Gantry Crane, Container Gantry Crane, Project Crane, 2017

Weston Solutions, and San Diego State Geography Department. "Learn about the San Diego Bay Watersheds." San Diego Bay Watersheds Common Ground- Learn About the Watersheds, 2018

Souder, Chris. Temporary Structure Design. John Wiley & Sons, 2015

Hamada, T., Sugawara, K., Tanaka, K., & Kanai, M. (2017). U.S. Patent No. 9,672,743. Washington, DC: U.S. Patent and Trademark Office.

He, S., Salem, O., & Salman, B. (2017, January). An asset management framework for ramp metering system and adaptive traffic control systems. In 9th International Structural Engineering and Construction Conference: Resilient Structures and Sustainable Construction, ISEC 2017. ISEC Press.

Kanai, M., Katou, M., & Hamada, T. (2019). U.S. Patent No. 10,446,036. Washington, DC: U.S. Patent and Trademark Office.

Lu, M., & Zhao, T. (2018). Impact Analysis of Temporary Traffic Control Design in Planning Construction for Transportation Infrastructure Expansion: the Contractor's Perspective (No. 18-03438).

Ram, P., & Smith, K. (2017). Traffic Control Strategies for Concrete Pavement Rehabilitation and Reconstruction (No. FHWA-HIF-17-007).

Saha, T., & Sisiopiku, V. P. (2020). Assessing Work Zone Traffic Control Options for 3-to-1 Lane Closures. Journal of Transportation Technologies, 10(01), 50.

Zhang, F., & Gambatese, J. A. (2017). Highway construction work-zone safety: Effectiveness of traffic-control devices. Practice Periodical on Structural Design and Construction, 22(4), 04017010.

Biomassone-how-much-material. April 17,2017.

RSMMeans data is North America's leading construction estimating database. Nov 11,2019

Codes:

- a) American Concrete Institute (ACI) and American Institute of Steel Construction (AISC) Manuals.
- b) American Association of State Highway and Transportation Officials (AASHTO) Standard Specifications.
- c) Federal Highway Administration Load and Resistance Factor Design for Highway Bridge Superstructures (LRFD)
- d) Golder Associates and James F. Maclaren Ltd., 1976, Tunneling Technology: An Appraisal of the State of the Art for Application to Transit Systems.
- e) The American Society for Testing and Material Standards (ASTM)
- f) Technical Manual for Design and Construction of Road Tunnels.



Appendix 1: Geotechnical Study Report



Coronado NAB Pedestrian Tunnel

Final Design Submittal by Civil Creations Inc.

Team 22

May 6th, 2020

Table of Contents

Appendix 1: Geotechnical Study

1.1 Soil Classification Study and Soil Layer Analysis.....	10
1.1.2 Groundwater.....	12
1.2 Underground Tunnel Structural Design Requirements.....	13
1.3 Tunnel Foundation Lateral Resistance.....	13
1.4 Development Analysis.....	13
1.5 Development Constraints.....	14
1.6 Soil Bearing Capacity.....	15
1.7 Geologic Hazards.....	15
1.7.1 Faulting and Seismicity.....	15
1.7.2 Ground Surface Rupture.....	15
1.7.3 Ground Shaking.....	16
1.7.4 Liquefaction and Seismically Induced Settlement.....	16
1.7.5 Lateral Spreading.....	16
1.8 Tunnel Structural Fill Material and Fill Compaction.....	16
1.9 Foundation Recommendations.....	17
1.10 Tunnel Wall Drainage.....	17
1.11 Seismic Wall Design.....	18
1.12 Tunnel Bedding.....	20
1.13 Tunnel Grading.....	20
1.14 Recommendations.....	21
1.15 Calculations.....	22

List of Figures

Figure 1.2 : Boring Data.....	11
Figure 1.3: Boring Data.....	12
Figure 1.4: Polyethylene Drainage Location.....	18
Figure 1.5: Soil Pressure Diagram.....	26

List of Tables

Table 1.1: Soil Classification.....	10
Table 1.2: Seismic Factors.....	19

1.1 Soil Classification Study and Soil Layer Analysis

Soil samples were available through Ninyo & Moore to Civil creations Inc. and a geotechnical evaluation was conducted. According to Ninyo & Moore, several tests were made that included dry density and moisture content, sieve analysis, swell-consolidation, and water-soluble sulfate content tests. To assess possible heaves, the swell test tests were wetted at different applied weights, which provided the overburden pressure approximates. During the investigations, at around 3 to 7 feet thick there was a layer an existing, was experienced at the ground surface in the two borings. The brown and dark gray damp to saturated, loose to medium dense, poorly-graded sand with silt, silty sand, and sandy silt was the composition of fill as shown in **Table 1** (Ninyo and Moore, 2008).

RELATIVE DENSITY OF COARSE GRAINED SOILS (More than 50% retained on No. 200 sieve.) Density determined by Standard Penetration Resistance Includes Gravels, sands and silts.		CONSISTENCY OF FINE-GRAINED SOILS (50% or more passing the No. 200 sieve.) Consistency determined by laboratory shear strength testing, field visual-manual procedures or standard penetration resistance		
Descriptive Term (Density)	Standard Penetration or N-Value Blows/Ft.	Descriptive Term (Consistency)	Unconfined Compressive Strength, Qu, psf	Standard Penetration or N-Value Blows/Ft.
Very Loose	0 - 3	Very Soft	less than 500	0 - 1
Loose	4 - 9	Soft	500 to 1,000	2 - 4
Medium Dense	10 - 29	Medium-Stiff	1,000 to 2,000	4 - 8
Dense	30 - 50	Stiff	2,000 to 4,000	8 - 15
Very Dense	> 50	Very Stiff	4,000 to 8,000	15 - 30
		Hard	> 8,000	> 30

Table 1: Soil Classification

Brown, damp to moist, medium dense silty, scattered shell fragment sand was experienced underneath the current fill in the boring TH-1 at 10 feet below the existing ground. The earth was moist to wet dependent on field infiltration obstruction tests. Two examples of the mud tried in our research center displayed low estimated swell estimations of 0.1 and 0.2 percent when wetted under-evaluated overburden pressure. Dark gray, saturated, loose, silty fine sand was discovered at around 16 feet under the fill layer using the boring TH-2. Dark gray, saturated, dense, poorly

graded fine sand with silt, micaceous was found at 25.3 ft. depth as shown in **Figure 2** and **Figure 3**.

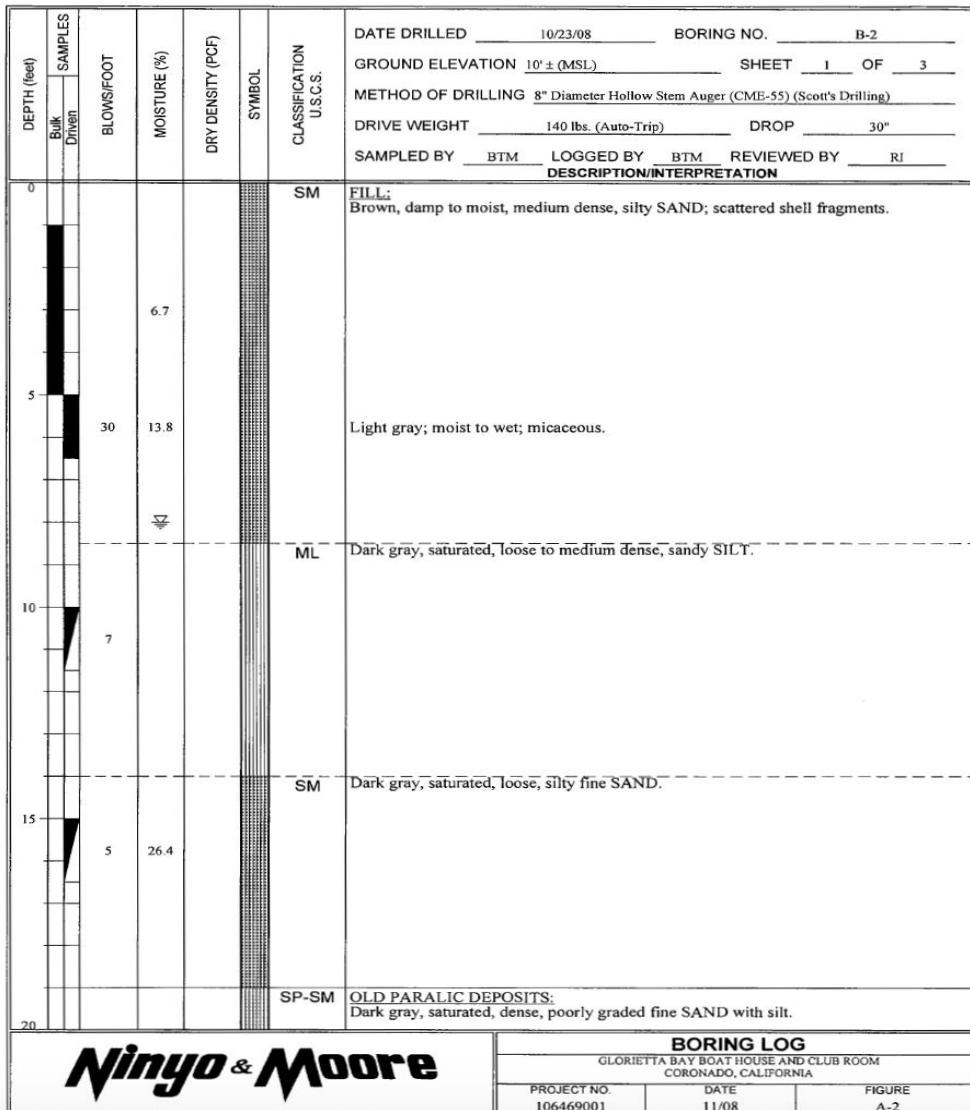

Figure 2: Boring Data 1

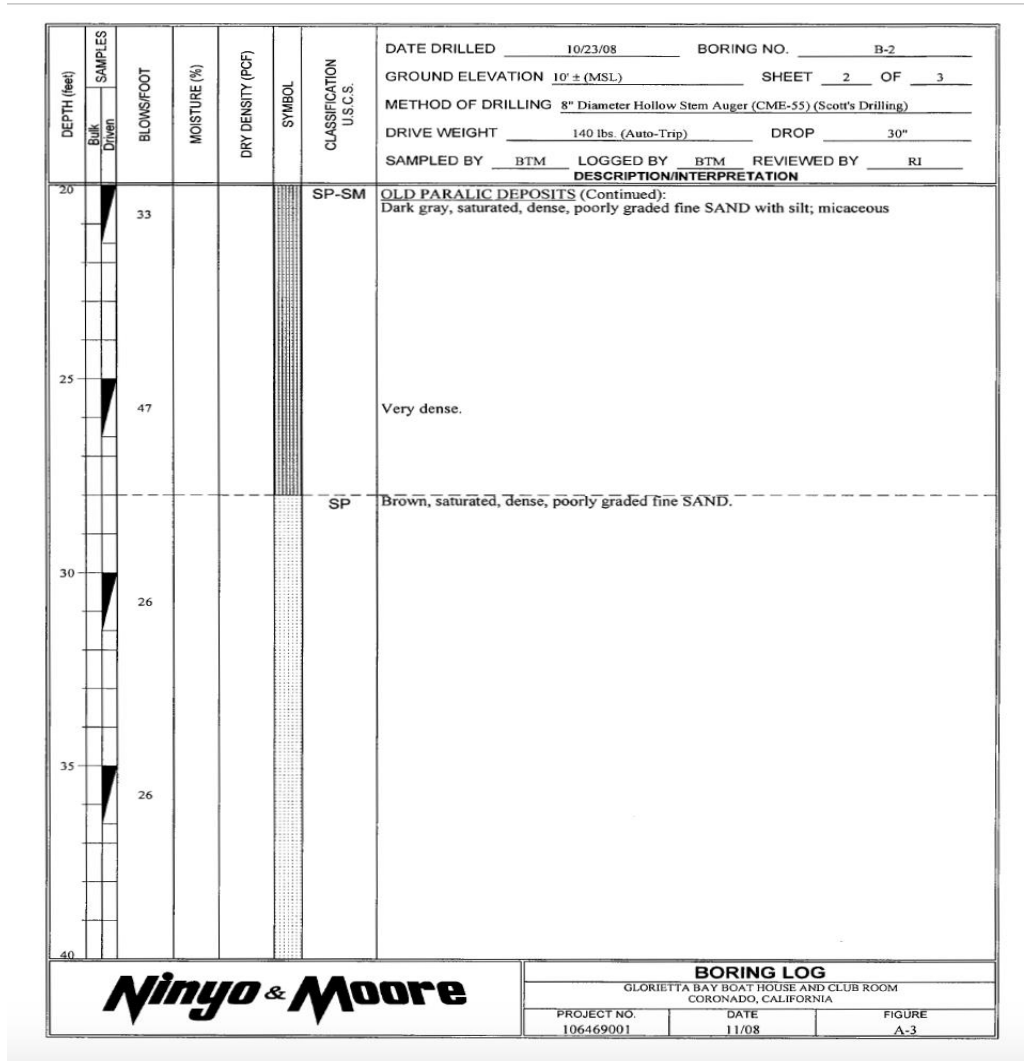

Figure 3: Boring Data 2

1.1.2 Groundwater

According to Ninyo & Moore groundwater was encountered in the bore at a depth of approximately 7ft. Also, due to tidal fluctuations and subsurface geologic conditions the groundwater depth observed is not considered stabilized. Also, groundwater may rise to a level higher than the measures (Ninyo and Moore, 2008).

1.2 Underground Tunnel Structural Design Requirements/Concrete Requirements

The measured soluble sulfate concentration in one sample from the site at less than 0.1 percent. Concentrations of Sulfate that are below 0.1% indicate Class 0 exposure to attacks by sulfates for concrete coming in contact with the subsoil, based on the ACI 201.2R-01, provided by the 2008 American Concrete Institute (ACI) Manual of Concrete Practice (American Concrete Institute, 2008). Having such levels of concentrations of sulfate, the Type I/II cement is recommended by ACI for use for concrete that is likely to get in contact with the underlying subsoil. Based on construction experience, there may be instances of superficial damage occurring to the exposed surfaces made of highly permeable concrete, even though sulfate levels may be considerably at lower levels.

1.3 Tunnel Foundation Lateral Resistance

The foundation resistance to horizontal loads, it is suggested a permissible passive weight applied by a proportionate water pressure load of 300 pounds for each cubic foot should be utilized. This worth accept that the ground is level for a separation of 10 feet or more, or multiple times the stature producing the passive weight, whichever is more noteworthy. It is prescribed that the upper I foot of soil not secured by asphalt or a solid section be dismissed while computing the resistance. The frictional resistance from lateral loads, a coefficient of contact of 0.35 is recommended for utilization among soil and cement. On the off chance that detached and frictional protections are to be utilized in the mix, we suggest that the inactive worth not surpass one-portion of the absolute obstruction. However, the resistance loads provided might be expanded by 33% when factoring in short duration loads like the wind or seismic loads (Marinos, 2019). The soil pressure will dictate the load requirements in terms of tunnel sizes and concrete reinforcements.

1.4 Development Analysis

Underground pedestrian tunnels have been in use for years in various cities. Separating pedestrian and vehicle traffic, to shield pedestrians from inclement weather and add a new level of retailing to encourage downtown development has been done in many large cities. Underground pedestrian systems function as a medium by linking transport, working and leisure

places together in integrated spaces with a variety of functions to create an urban synergy. Adopting a systems approach to analyzing urban pedestrian space helps to conceptualize the relationship between underground pedestrian systems and other pedestrian spaces within the broader urban environment Cui, 2015).

In general, there are three main benefits of developing an underground pedestrian tunnel link in Coronado California. Firstly, viewing the city as a complex system, an underground pedestrian system is a vital subsystem of public space systems, expanding space and movement below the surface pedestrian systems. Secondly, an underground pedestrian system uses walking as a mode of transport to link and aggregate activities such as retailing and mass transit within an underground setting. Thirdly, an underground pedestrian system has an important functional feature through the provision of underground public passageways functioning as a medium that integrates ground level spaces with underground spaces (Cui, 2015).

1.5 Development Constraints

All underground excavations during tunnel constructions cause pressure redistribution in the ground, which prompts ground misshaping. Moderating the related hazard is a basic factor during the tunnel plan procedure. Albeit different decisions can be made during the plan procedure to lessen the danger of harm to contiguous structures, instrumentation checking of existing structures is a basic piece of the development procedure to give a quantitative evaluation of the burrowing activity and choose development technology. The gathered field estimations can likewise be utilized to refine the plan findings and change development systems if fundamental (Vakili, 2019).

Ground deformation observation is critical for shallow urban tunnel development with a slurry or earth pressure balance shield. Experimental conditions and numerical displaying, with examinations guided by point of reference ventures, are ordinarily utilized at the structure stage to evaluate the ground development due to burrowing and for deciding suitable TBM face pressures. During development, gathered information on ground change is surveyed against anticipated qualities. This may bring about recently performed investigations being changed and TBM task parameters being balanced. Gathered ground-change information can likewise be useful for any passage venture that may be built later on (Baker, 2019).

1.6 Soil Bearing Capacity

The construction site is characterized by brown and dark gray damp to saturated, loose to medium dense, poorly-graded sand with silt, silty sand, and sandy silt was the composition of the fill. An allowable bearing pressure of 2,000 pounds per square foot (psi) is recommended for use in foundations constructed on this fill. The allowable bearing capacity can be increased by one-third when considering loads of short duration such as wind or seismic forces. A design coefficient of subgrade reaction, of 120 pounds per cubic inch may be used for evaluating deflections at the subject sites.

1.7 Geologic Hazards

Coronado California is a seismically active therefore seismic hazard such as ground rupture and shaking resulting from seismic activity, liquefaction, lateral spreading, and dynamic settlements were considered during this project.

1.7.1 Faulting and Seismicity

The site falls under the seismic active Zone 4 but the review of the past geological maps and literature reveals that the site is not subject to any active or potentially active faults as there is no evidence pointing at ground movement over the past 11,000 years or 11,000-2,000,000 years respectively. This site falls out of the State of California Alquist-Priolo Special Studies Zone for faults resulting from an earthquake. The seismic event of great significance on this tunnel construction is the magnitude 7.2 earthquake on the Rose Canyon fault that is located about one mile to the northeast of the tunnel construction site.

1.7.2 Ground Surface Rupture

The damage on the tunnel due is low as there is no evidence of active faults around the site. There are possibilities of damages like cracking due to shaking from far vents, but this remains an insignificant seismic hazard to the tunnel.

1.7.3 Ground Shaking

Analysis by Ninyo & Moore on the project site estimates a modified Design Earthquake (PGA_{DE}) of 0.62g based on the United States Geological Survey and the web-based ground motion calculators and the design earthquake for the site to be 0.41g. The estimations were based on the recommendations by California Building Code-2007 which requires structural designs to be based on the maximum ground acceleration of a 2% probability of exceedance in fifty years, that is, the Maximum Considered Earthquake.

1.7.4 Liquefaction and Seismically Induced Settlement

Analysis of the liquefaction potential based on the modified GA_{DE} and assumed granular subsurface soils lying below the highest groundwater table, revealed a liquefaction potential of up to 19 feet deep below the existing grades. It was therefore estimated that a dynamic settlement of about 4 inches is possible due to seismic events occurring in the site vicinity. In general 2 inches, differential dynamic settlement can be expected over a depth of 40 feet in the construction site (Ninyo and Moore, 2008).

1.7.5 Lateral Spreading

Studies associate lateral spreading with occurrence in the free face direction typically the retaining wall, channel or slope but minimum in the gently sloping grounds. The distance of the construction site from the epicenter of an earthquake and the liquefiable layer thickness also contribute factors of lateral spreading. This site is subject to effects of nearby earthquake events, has a considerably high thickness of liquefiable layers and its distance to Glorietta Bay, a free face, there exists the potential for lateral spreading at the tunnel construction site.

1.8 Tunnel Structural Fill Material and Fill Compaction

Fill material should not contain rocks or lumps over approximately 4 inches in diameter, and not more than approximately 30 percent larger than a quarter inch. Utility trench backfill material should not contain rocks or lumps over approximately 3 inches in general. Imported fill material should generally be granular soils with a very low to low expansion potential and non-corrosive.

Before placement of compacted fill, the ex-posed ground surface should be scarified, moisture conditioned as needed to achieve moisture contents generally above the optimum moisture content, and then compacted to relative compaction of 90 percent as evaluated per ASTM D 1557 (ASTM, 2012).

1.9 Foundation Recommendations

Civil Creation Inc. recommend the use of continuous footings founded on compacted fill. The continuous footing supports the tunnel walls bearing on re-compacted fill and may be designed using an allowable bearing capacity of 2,000 psi. This allowable bearing capacity may be increased by one-third when considering loads of short duration such as wind or seismic forces. The continuous footings should have a width of 15 inches and should be reinforced following the recommendations of the project structural engineer.

Also, an allowable passive pressure exerted by an equivalent fluid weight of 300 pounds per cubic foot be used for the resistance of foundations to lateral loads. This value assumes that the ground is horizontal for a distance of 10 feet or more, or three times the height generating the passive pressure, whichever is greater.

1.10 Tunnel Wall Drainage

This underground tunnel will utilize the conventional wall or surface drainage method. This method uses large foamed polythene mats that are mounted on steel rods placed at adequate distances in the wall of the tunnel. Water leaking from the tunnel walls drips on the polythene mat, running down along the wall drains to the drainage channels at the bottom of the tunnel. The polyethylene mat is then covered with shot-concrete due to its sensitivity to mechanical damage and susceptible to fire to its high flammability. The drainage mats are used to assemble and fixe on the threaded rods using different steel materials. Finally, the polyethylene drainage mat was covered with two layers the first being a 60 mm thick shot-concrete layer reinforced with steel polypropylene fibers and followed with another 20mm thick layer of concrete mixed polypropylene fibers as shown in **Figure 4**.

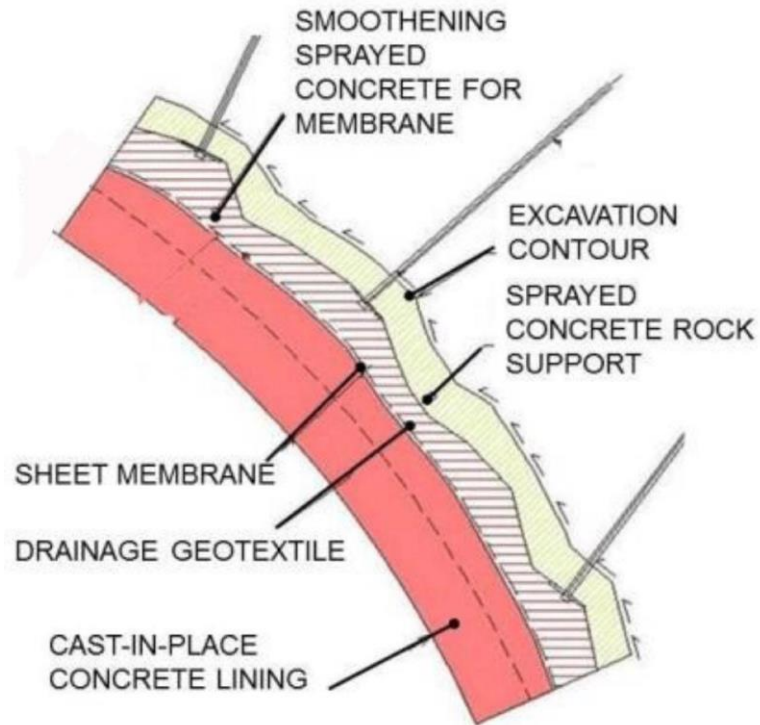

Figure 4: Polyethylene Drainage Mat Location

1.11 Seismic Wall Design

Coronado California corresponds to Seismic Zone 4, therefore, the Seismic Design Parameters for the design of the tunnel wall was according to the design for structures located in Seismic Zone 4 and the appropriate American design standards. The seismic design parameters corresponding to the site are provided by California Building Codes and mapped spectral acceleration parameters based the United States Geological Survey. **Table 2** provides the various seismic factors for consideration in the tunnel wall design.

Factors	Values
Site Class	D
Site Coefficient, F_a	1.000
Site Coefficient, F_v	1.500
Mapped Short Period Spectral Acceleration, S_s	1.552g
Mapped One-Second Period Spectral Acceleration, S_1	0.616g
Short Period Spectral Acceleration Adjusted Fr Site Class, S_{MS}	1.552g
One-Second Period Spectral Acceleration adjusted For Class, S_{M1}	0.924g
Design Short Period Spectral Acceleration, S_{DS}	1.035g
Design One-Second Period Spectral Acceleration, S_{D1}	0.616g

Table 2: Seismic Factors

1.12 Tunnel Bedding

Civil Creation Inc. will excavate up to 22 feet outwards from the continuous footing or to the point that is practically fit. The on-site earth materials were suitable for use as bedding backfill so long, they are free from organic material, debris, clay clumps and rocks having a diameter greater than 3 inches. Backfill must be compacted to relative compaction of 90 percent except for the upper 12 inches of the backfill that are compacted to relative compaction of 95 percent as evaluated by ASTM D 1557. Also, the backfill materials or beddings must conform to the requirements for structural backfill by the Standard Specifications for Public Works. soils that are present on top of tunnel are primarily fine aggregates, soils below tunnel are coarse grain soils including the bedrock.

1.13 Tunnel Grading

According to an analysis by Ninyo & Moore, the existing fill materials were considered compressible and not suitable for structural support in their present condition. The existing fill materials must be removed to a depth of approximately 22 feet below the existing grade. Placing gravel and stabilization geo-fabric at the bottom of the resulting excavations to stabilize the removal bottoms before receiving fill is recommended, with the resulting removal surface should then be scarified approximately 8 inches, moisture conditioned to near the recommended optimum moisture content

The tunnel grading is important for the safety and comfort of the users including pedestrians on foot and cyclists utilizing the channel as a separate grade for safety during road crossing. A maximum grade of 3.5% is recommended for tunnels utilized by motorists for maximum safety. However, for tunnels limited to cyclists and pedestrians a maximum grade of 5% is recommended. Therefore, a grade of 3.5% should be maintained during the remedial grading process, involving the removal of existing fills and replacements with appropriate fill and subsequent compactions.

1.14 Recommendations

This report finds no significant geotechnical condition that can stop the implementation of the project in terms of stability and safety provided that the recommendations are incorporated in the design of the tunnel. Generally, the following conclusions were made:

- The construction site is characterized by brown and dark gray damp to saturated, loose to medium dense, poorly-graded sand with silt, silty sand, and sandy silt was the composition of the fill.
- Groundwater exists at a depth of approximately 7 feet but is subject to fluctuations due to tidal fluctuations and subsurface geologic conditions.
- The existing fill materials in the site are not suitable and should be excavated out to at least 22 feet below existing ground levels. The excavations can, however, be done up to designed levels in consideration of other factors.
- The excavated soils from the site are suitable for re-use as fill materials so long as the requirements for fill compactions are met.
- An allowable soil bearing pressure of 2,000 pounds per square foot (psi) is recommended for use in foundation design and constructed on the fill.
- The tunnel construction site is in the vicinity of the magnitude 7.2 earthquake on the Rose Canyon fault therefore strong seismic designs must be considered in the design.
- The site is subject to liquefaction and seismically induced settlement. A dynamic settlement of about 4 inches is estimated due to seismic events occurring in the site vicinity with 2 inches differential dynamic settlement in every 40 feet depth. Therefore, possibilities of surface cracking and ground rupture.

1.15 Calculations

Based on the soil classification chart, sandy with silt is a coarse-grained soil, void ratio (e) for sandy clay soil = 0.55

Volume of Solids (V_s) = $1 + e = 1 + 0.55 = 0.645 = \mathbf{64.5\% \text{ of sample is voids}}$

Weight of Solids = $\gamma_{\text{water}} \times S.G \times V_s$

Weight of Solids = $62.4 \text{ pcf} \times 3.5 \times 0.645 = \mathbf{140.87 \text{ Pcf}}$

Submerged Unit Weight = $W_s - (\gamma_{\text{water}} \times V_s)$

Submerged Unit Weight = $140.87 \text{ pcf} - (62.4 \text{ pcf} \times 0.645) = \mathbf{100.62 \text{ Psf}}$

Foundation Calculations:

A- $16\text{ft} \times 10\text{ft} \times 0.833\text{ft} = 133 \text{ ft}^3 \approx 4.92 \text{ yd}^3$

B- $108\text{ft} \times 20\text{ft} \times 0.833\text{ft} = 1799 \text{ ft}^3 \approx 66.6 \text{ yd}^3$

C- $70\text{ft} \times 10\text{ft} \times 0.833\text{ft} = 583 \text{ ft}^3 \approx 21.6 \text{ yd}^3$

Foundation Total = 94 yd^3

Grading and Soil Compaction Calculations:

A- $16\text{ft} \times 10\text{ft} \times 0.67 = 107.2 \text{ ft}^3 \approx 3.97 \text{ yd}^3$

B- $108\text{ft} \times 20\text{ft} \times 0.67 = 1447 \text{ ft}^3 \approx 53.6 \text{ yd}^3$

C- $70\text{ft} \times 10\text{ft} \times 0.67 = 569 \text{ ft}^3 \approx 21.1 \text{ yd}^3$

Grading and Soil Compaction Total = 78.67 yd^3

In order to support the active soil pressure, Shoring design falls into this category because the purpose is to support the excavation or trench with adequate support that resists collapse and minimizes deflections and settlement as shown in **Figure 5**.

The value of active soil pressure coefficient should always be less than 1.000. Cohesion (Φ) = 25° . $C = 275$.

$K_a = 1 - \frac{\sin \Phi}{1 + \sin \Phi} = 1 - \frac{\sin 25^\circ}{1 + \sin 25^\circ} = \mathbf{0.41}$

When soil is loading a structure, the pressure develops at a depth of 22 ft.

$$P = \gamma \times h \times K_a - 2 \times c \times (\text{square root } K_a)$$

$$P_{\text{Top}} = 100.62 \text{ pcf} \times 0 \times 0.41 - 2 \times 275 \times (\text{square root}(0.41)) = \mathbf{-352.17 \text{ psf}}$$

$$P_{\text{bottom}} = 100.62 \text{ pcf} \times 22 \text{ ft} \times 0.41 - 2 \times 275 \times (\text{square root}(0.41)) = \mathbf{555.42 \text{ psf}}$$

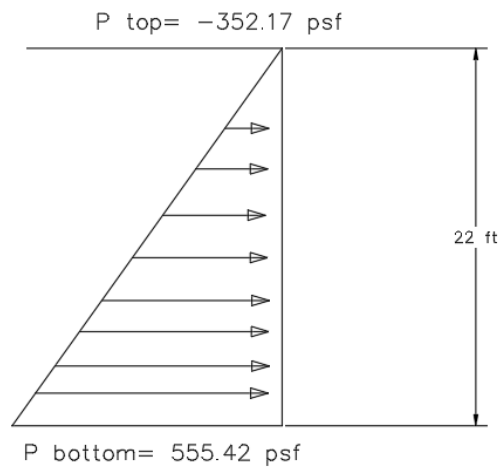
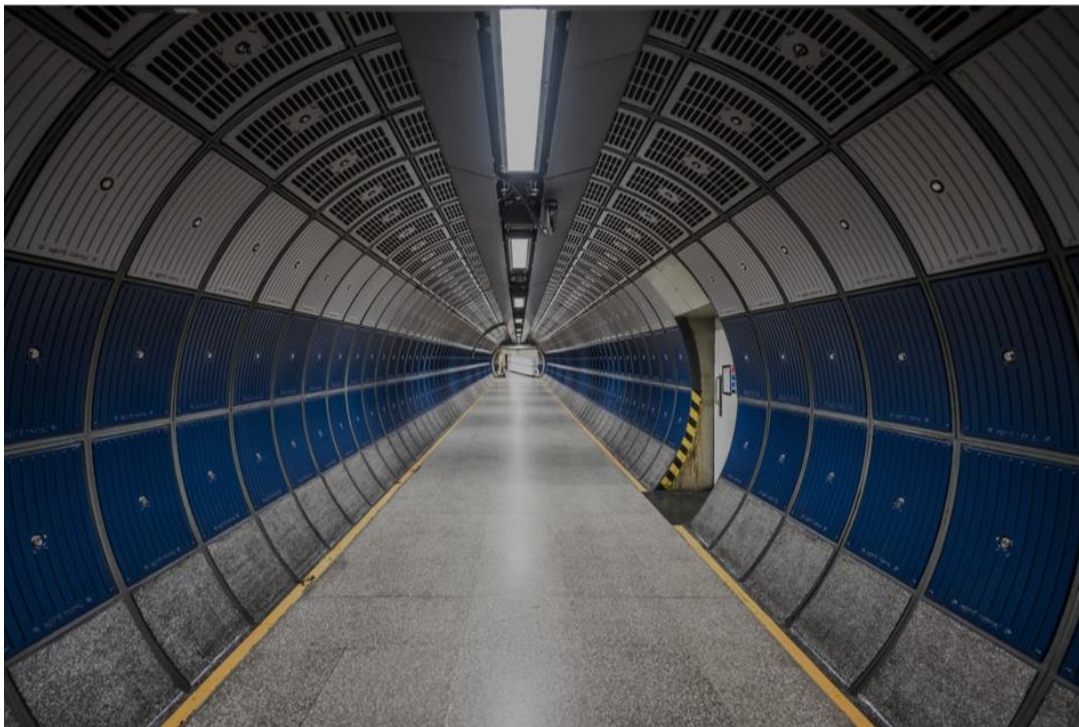

Figure 5: Soil Pressure Diagram



Appendix 2: Storm Water Study Report



Coronado NAB Pedestrian Tunnel

Final Design Submittal by Civil Creations Inc.

Team 22

May 6th, 2020

Table of Contents

Appendix 2: Stormwater Study

2.1 Storm Water Study.....	28
2.2 Drainage Study.....	29
2.3 Runoff Calculations.....	30
2.4 Existing Basin Calculation.....	32
2.5 Proposed Basin Calculation.....	33
2.6 Water Reuse and Recommendations.....	34
2.7 Techniques for Reducing Storm Flows.....	34
2.8 Scope of Work.....	35
List of Figures:	
Figure 2.6: Land Use Percentage.....	28
Figure 2.7: Basin Location.....	29
List of Tables:	
Table 2.3: Hydrology Soil Group D.....	30

2.1 Storm Water Study

According to San Diego Basin Water Quality Control Plan (Manual 1994), Coronado island is part of the Otay River watershed (HUI 910.0) and covers approximately 160 square miles in southwest San Diego County and is one of the three watersheds that discharge to San Diego Bay (sdbay). “As shown in **Figure 6**, the land use in the watershed is primarily Undeveloped (39.8%), Residential (20.2%), and parks and recreation (24.6%). There is approximately 24.9% impervious surface” (Sdbay). The rainfall intensity in Coronado island is 9.4in/year (usclimatedata). In **Figure 7**, we have two inlets in our project site, and it is connected to the basin.

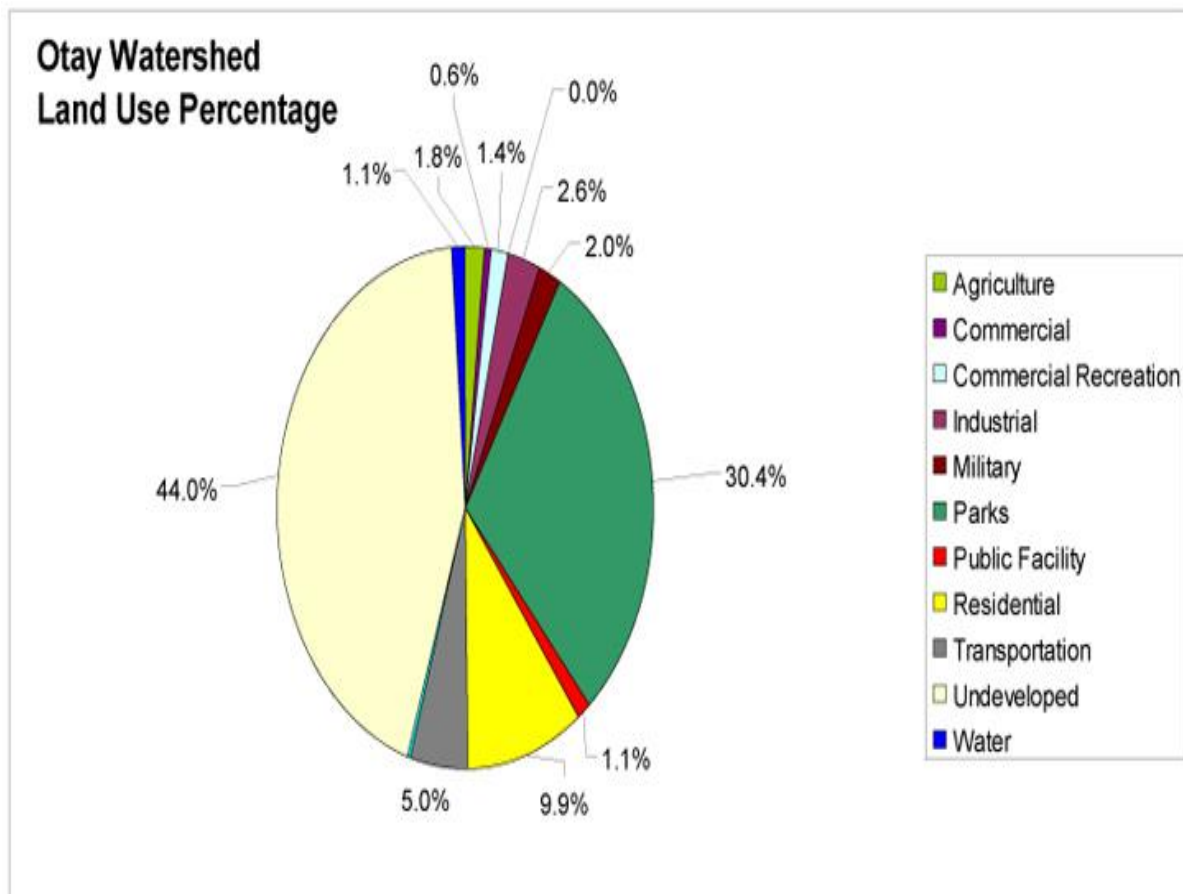

Figure 6: Land Use Percentage

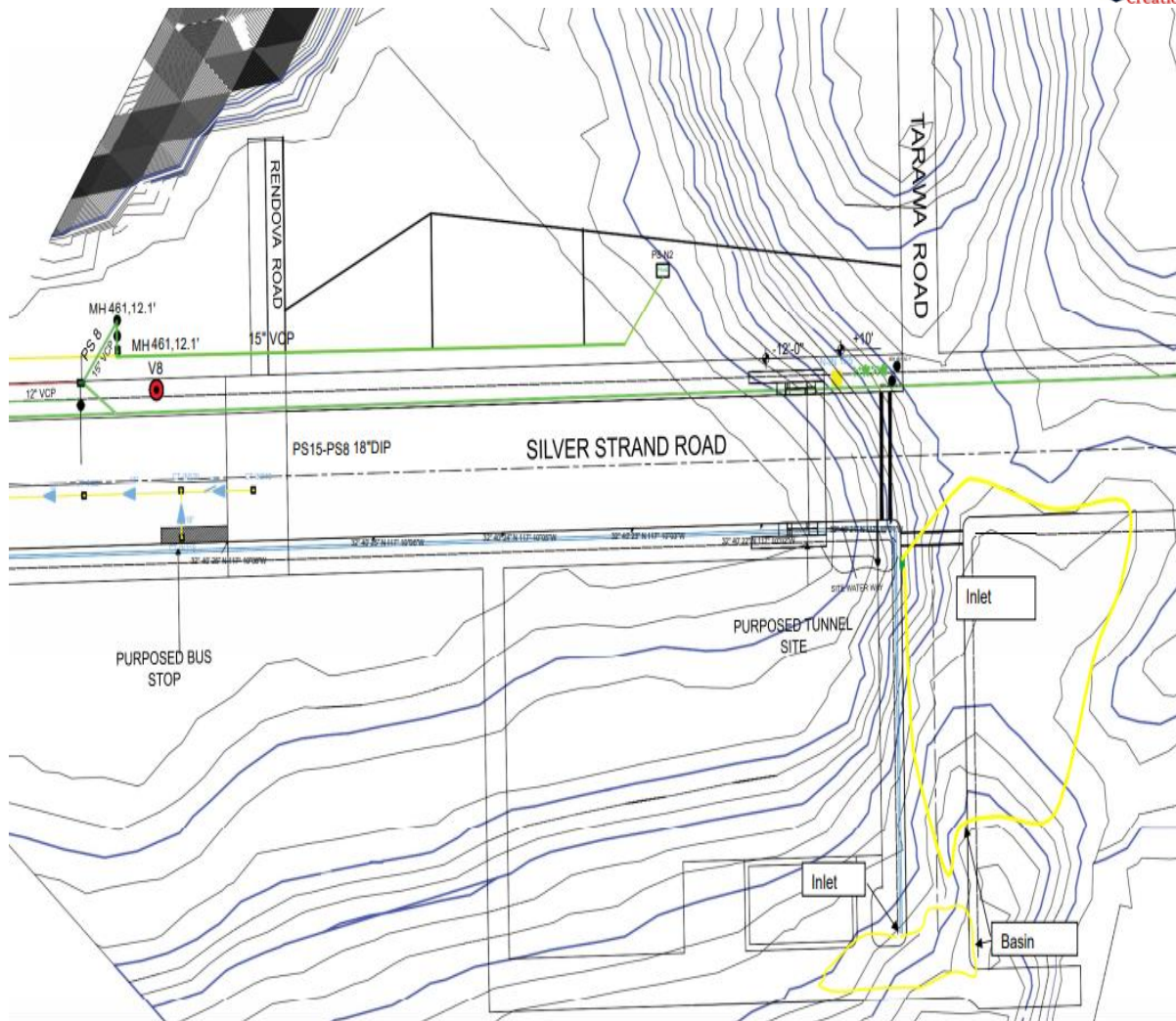

Figure 7: Basin Location

2.2 Drainage Study

Coronado Island is located within Otay River Watershed as defined by the San Diego Basin Water Quality Control Plan (1994) referred to as the Basin Plan. Based on our studies on the soil, the material generally consists of dark gray to brown saturated, dense to very dense, sand with silt and sandy silt and the hydrologic soil group is D. Therefore, consistent with the 1984 City of San Diego Drainage Design Manual (Manual), all calculations contained herein are based on this soil classification.

Group D soils are clay loam, silty clay loam, sandy clay, silty clay or clay. This HSG has the highest runoff potential. They have very low infiltration rates when thoroughly wetted and consist chiefly of clay soils with high swelling potential, soils with a permanent high-

water table, soils with a clay pan or clay layer at or near the surface and shallow soils over nearly impervious material as shown in **Table 5**.

Surface Type	Group D Runoff Coefficient
Pavements/Impervious surfaces	98
Gravel driveway/Road	91
Commercial building (NAB) approx. 1000 acres	72

Table 3: Hydrologic soil group D

2.3 Runoff Calculations

The drainage basin analyzed herein are less than one square mile and therefore runoff was calculated using the Rational Method, which is given by the following equation:

$Q = C \times I \times A$ Where:

Q= Flow rate in cubic feet per second (cfs)

C = Runoff coefficient

I = Rainfall intensity in inches per hour (in/hr)

A = Drainage basin area in acres (ac)

Time of Concentration - Times of concentration for drainage basins were calculated based on initial or overland flow time, shallow concentrated flow and channel flow to each inlet point. Initial time or overland flow time was calculated using the following equation:

$$T_i = [1.8 \times (1.1 - C) \times L^{1/2}] / S^{1/3}$$

Where:

T_i = Initial (Overland) time of concentration in minutes

C = Runoff coefficient

L = Length of travel of runoff in feet

S = Slope in percent

The travel time for shallow concentrated flow is a function of the water course length, surface condition, slope and resulting velocity. Based on surface conditions (paved or unpaved), assumptions can be made for Manning’s roughness coefficient and hydraulic radius resulting in the following equation:

$$T_s = [L / (C \times S^{1/2})] \times 60 \quad \text{Where:}$$

T_s = Sheet flow time of concentration in minutes

L = Length of travel of runoff in feet

C = Manning’s equation constant

= 16.1345 for unpaved surfaces

= 20.3282 for paved surfaces

S = Slope in feet per feet

Lastly, travel time for channel flow was calculated as a function of flow length and average velocity. Longitudinal slopes along with estimated peak discharges were used to determine average velocities. The length of flow over a segment of longitudinal slope was then divided by the average velocity to determine channel flow travel time. A minimum 5-minute time of concentration was used for runoff calculations and is based on the “Rainfall Intensity – Duration – Frequency Curves for County of San Diego” found in the Manual. Intensity - The intensity of rainfall was obtained from the “Rainfall Intensity-Duration-Frequency Curves for County of San Diego” found in the Manual.

2.4 Existing Basin Calculation

Flow Rate

$$Q = C \cdot I \cdot A$$

Given, A = 0.0819 Acres, and I = 9.4 in/yr = 9.4 in / 365 * 24 in/hr = 9.4 / 8760 in/hr

$$= 0.00107 \text{ in/hr}$$

C-values

For 45.1% impervious and residential area – 0.98

For 54.9% Undeveloped and parking area – 0.91

$$Q = C_1 * I * A_1 + C_2 * I * A_2$$

$$= 0.451 A I C_1 + 0.549 A I C_2$$

$$Q = 0.0819 * 0.00107 * (0.451 * 0.98 + 0.549 * 0.91)$$

$$Q = 8.27 * 10^{-5} \text{ cfs}$$

Time of Concentration (T_c)-

$$T_c = T_i + T_t$$

Where, T_i - Initial Time, and

T_t - Travel Time

C_{weighted}-Value

$$C = C_1 A_1 + C_2 A_2 / A_1 + A_2 = 0.98 * 0.451 * 0.91 + 0.549 * 0.0819$$

$$C_{\text{weighted}} = 0.94$$

Slope = 1%

Assumed Velocity = 5.1 fps

And, T_i = 9.5 minutes

Distance traveled = 460ft

$$T_t = \text{Distance} / \text{Velocity} = 460 / 5.1$$

$$= 0.81 \text{ minutes}$$

So, $T_c = 9.5 + 0.81 = 10.31 \text{ minutes}$

$$T_c = 10.31$$

2.5 Proposed Basin Calculation

Flow Rate

$$\begin{aligned}
 Q &= C \cdot I \cdot A && \text{(Rational method)} \\
 &= C_1 \cdot I \cdot A_1 + C_2 \cdot I \cdot A_2 \\
 &= 0.451 A I C_1 + 0.549 A I C_2
 \end{aligned}$$

Given, $A = 0.0819 \text{ Acres}$, and $I = 9.4 \text{ in/yr} = 9.4 \text{ in}/365 \cdot 24 \text{ in/hr} = 9.4/8760 \text{ in/hr}$

$$= 0.00107 \text{ in/hr}$$

C-values

For 45.1% impervious and residential area – 0.98

For 54.9% Undeveloped and parking area – 0.91

$$Q = 0.0819 \cdot 0.00107 \cdot (0.451 \cdot 0.98 + 0.549 \cdot 0.91)$$

$$Q = 8.27 \cdot 10^{-5} \text{ cfs}$$

Time of Concentration (T_c)-

$$T_c = T_i + T_t$$

Where, T_i - Initial Time, and

T_t - Travel Time

C_{weighted} -Value

$$C = C_1 A_1 + C_2 A_2 / A_1 + A_2 = 0.98 \cdot 0.451 + 0.91 \cdot 0.549 / 0.0819$$

$$C_{\text{weighted}} = 0.94$$

Slope = 2%

Assumed Velocity = 8.3 fps

And, $T_i = 8.4$ minutes

Distance traveled = 460ft

$$T_t = \frac{\text{Distance}}{\text{Velocity}} = \frac{460}{498.3}$$
$$= \mathbf{0.94 \text{ minutes}}$$

So, $T_c = 8.4 + 0.9 = 9.3$ minutes

$$\mathbf{T_c = 9.3 \text{ minutes}}$$

Note: As the intensity in the project is given constant and it is 9.4in/yr. So, the storm water will be the same each year.

2.6 Water Reuse and Recommendations

Stormwater reuse entails storing storm water runoff in a surface pond or underground catchment device and then using it as a source of irrigation water. The philosophy behind the practice is that the lowest quality water should be used for the lowest quality need. Some of the potential of reusing stormwater and rainwater harvest and use systems can improve or maintain watershed hydrology, reduce pollutant loading to receiving waters, increase water conservation, reduce stress on existing infrastructure, and reduce energy consumption.

2.7 Techniques for Reducing Storm Flows

- Roof Drains- Discharge to grassed areas so that there would be more percolation and infiltration.
- Surface Grading- Use contour grading, detention ponds.
- Paving – Porous pavements of asphalt, interlocking blocks, gravel
- Ditches- Grassed ditches.

2.8 Scope of Work

Work area shall be cleaned of all debris at the end of each workday.

The contractor shall provide materials & safety equipment and all required tools and equipment to complete the project.

The contractor shall provide a work schedule showing starting and completion of the project and the date and time planning to work in the residence yard.

After hours and weekend work may be required. This will be determined by the Facility Management Officer. Normal working hours shall be 0800 to 1630 hrs.

The contractor shall protect all existing surfaces and existing trees and lawns from damage. Protection materials provided by the contractor. Maximum care should be taken while excavation to avoid damages to other underground services. Concrete and paved areas should be restored to its original state & shape after the job is completed. Irrigation systems shall be repaired, replaced or added to where necessary. The Contractor will repair or replace at his own cost if anything is damaged due to the negligence of the contractor.

Only those materials approved by the Facility Management Officer will be used. Contractor must provide samples, at the request of the Facility Management Officer.

Work should be done causing minimum disturbance to the tenant. When working on main drainage lines, bowser trucks should be used to lift-up the sewage water to avoid overflowing the drainage manholes into the property.

The construction of new manholes should be in accordance with the local standards and codes and removable drainage manhole covers should be used. Old redundant manholes should be demolished prior to backfilling. Any manholes require repair or smoothing the drain channels shall be done by the contractor. Manholes shall be raised or lowered to meet the new level of interlock pavers.



Appendix 3: Traffic Control Study Report

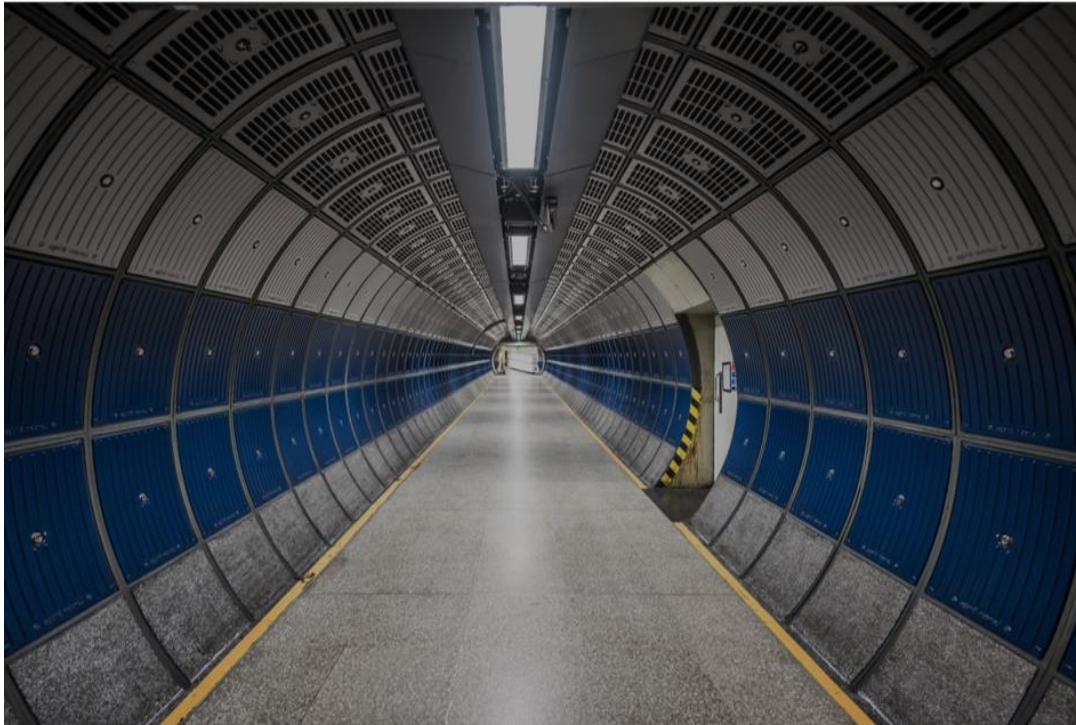

Coronado NAB Pedestrian Tunnel

Final Design Submittal by Civil Creations Inc.

Team 22

May 6th, 2020

Table of Contents

Appendix 3: Traffic Control Study

3.1 Introduction.....	36
3.2 Nature of the Road and the tunnel.....	36
3.3 TRAFFIC CONTROL MEASURES FOR TUNNEL AT SR-75 ROAD.....	38
3.4 Signage control measures.....	38
3.4.1 Stop Signal.....	39
3.4.2 Diversion signal.....	39
3.4.3 Flexible orange reflective soft PVC Traffic cones.....	40
3.4.4 Traffic safety ABS ceramic studs.....	40
3.4.5 Flashlight solar-powered traffic road studs.....	40
3.4.6 Billboard signage.....	41
3.5 Temporary Concrete Barriers to Control Traffic.....	41
3.6 Sidewalk Access for Limited Road Users.....	42
3.7 A street Detours control system.....	44
3.8 Use of flaggers to control traffic.....	44
3.9 Temporary shifts of the lane for controlling traffic.....	45
3.10 Conclusion.....	46
List of Figures	
Figure 3.8 Proposed Bus Stop Location.....	37

Appendix 3: Traffic Control Study

3.1 Introduction

Traffic control is an important aspect, especially in a construction project that would interfere with the usual traffic of a busy road (Hamada et al., 2017). Typically, Tarawa road construction along the SR-75 lane in Coronado is an interruption that would cause disturbance to the normal flow of traffic in the area. It is worthy to identify the best measures and control the adversities as necessary. Traffic control would be a good option to assist in the normal processes in Coronado since it would focus on policy implementations as needed. The main project, in this case, is the Coronado NAB Pedestrian Tunnel in San Diego, CA. The project is crucial since it would alleviate the country of jams and other inconveniences associated with the confusion of crossroads and the challenges that relate to the same. Traffic control requires an imminent approach to consider all the factors and ensure that none is violated for perfect and necessary control of the flows as needed (Hamada et al., 2017). In a better way, traffic control should always be effective to ensure that everyone goes about their businesses perfectly without any interruption. A perfect consideration of the approaches is the necessary mitigation of challenges and the promotion of a competent and strategic measure as needed. The following report is about traffic control techniques and measures to assist in seeing the project through a difficult process:

3.2 Nature of the Road and the tunnel

The tunnel is supposed to be an intersection of the SR-75 road to assist in the crossing of the pedestrians. Since currently there are several delays, our company decided to construct the tunnel and reduce the inconveniences associated with the crossing pedestrians. As a strategy, the road will be under modification whereby a tunnel will be inserted to assist in a perfect control strategy as needed.

the tunnel will cross the SR-75 road and result in several inconveniences. As an intersection, several activities that usually occurred in the road will be paralyzed or under restrictions to assist in the smooth flow of the traffic. It is in order to facilitate a good control mechanism so that the business in the area can go as normal as possible. Road crossing will be interfered with temporarily and needed intervention would be required to control the traffic and ensure that basic approaches applied in the successful management of the flow as required by the ministry of

transport (Hamada et al., 2017). The Tarawa road will be a major concern, especially based on the maneuvers to accommodate more traffic following the interruptions caused by the same. Better planning is, therefore, necessary to assist in the mitigation of challenges and promote a good strategy in the elimination of adversities as needed. **Figure 8** shown how it will be laid down for facilitation of the tunnel construction:



Figure 8: Proposed Bus Stop Location

Following the construction, the bus stop will be altered and made to mandatorily follow the restriction and be moved to the proximity of Rendova Road. SR-75 is a big highway and must be considered in the construction as a major target when it comes to the measures put in place. The best mechanisms require that appropriate and fundamental approaches are applied in the promotion of competent and effective strategies as required. Post the Pedestrian tunnel, the bus stop will be placed to assist in reducing some of the inconveniences.

The main challenge is traffic control during the process that will take place for a couple of months to complete. The rules of construction require that tunnels are constructed with concrete and made to strongly surface the area and support heavy weight truck. The project must therefore be given ample time to mature and get facilitated in a better and quality way for mitigation of the challenges and promotion of better strategies.

Based on the applied protocols, it would be a good strategy to promote an effective strategy and ensure that comprehensive measures are implemented in the control. Since the nature of the road is seen to be busy, the following are some of the control measures that will assist in integrated control and quality management of the roads as needed:

3.3 Traffic Control Measures for Tunnel at SR-75 Road

Considering the nature of the road and the level of traffic that it experiences, there is a need to focus on the control strategies that will not be self-limiting and compromising businesses and the level of organization (Hamada et al., 2017). Although there will be a deviation from the normal traffic since the pedestrian crosses a critical place at the SR-75 road, it is necessary to sacrifice and have a short-lived hindrance before an active process is implemented for a successful and effective strategy in reduction of the challenges. Better measures are needed to control the traffic and assist in the mitigation of challenges by focusing on the identification of control strategies that are necessary for the mitigation of adversities as needed. The following are some of the traffic control mechanisms that will be efficient to control the level of heavy traffic in the area:

3.4 Signage control measures

In a sophisticated world, especially the transport sector, the use of signals is important in issuing direction and promoting orderliness (Hamada et al., 2017). As a traffic control measure, the signage would be an essential measure to assist in the mitigation of the traffic inconveniences that result from the construction of the intersection tunnel at SR-75 road. The signals must be strategically placed to promote the quality and competent direction of the traffic users so as to limit the level of flow of the traffic in the area. There are significant signals that can be implemented in the promotion of better and comprehensive control strategies required in the mitigation of challenges as needed. A good measure in the mitigation of challenges requires that better and fundamental strategies are followed in the reduction of adversities associated with the construction process.

It is possible to encounter accidents in the incidents where construction goes on without enough signals of the interference with the normal traffic flow. A good measure requires that better strategies are implemented in the eradication of challenges and the promotion of a competent and

effective measure in the elimination of adversities as needed. Signage involves an amalgamation of the symbols used in traffic control to assist in the mitigation of the challenges and promotion of a competent traffic control approach as needed. The following are some signals that can be applied prior to the pedestrian construction tunnel along the SR-75 road to limit the challenges and promote a competent and effective strategy in reducing the traffic flow as needed:

3.4.1 Stop Signal

The motorists would understand the stop signal better and consider a second thought of following another route (Hamada et al., 2017). With the danger sign associated with the STOP signal, traffic would be controlled during the active phase of the construction process of the tunnel. Implementing better mechanisms in controlling the traffic challenge would be considered an effective strategy for the elimination of adversities as needed. Necessarily, it would be good to consider a good strategy and ensure that better techniques are implemented for comprehensive and necessary control strategies as needed. Motorists, cyclists, and pedestrians take the signal seriously in a manner that they follow the instruction that follows the signal placed for purposes of eliminating and reducing the chances of compromising the processes.

3.4.2 Diversion signal

Among the plethora of signals, the SR-75 road should have a diversion, point, and a signal indicated to allow the construction to take place smoothly and in a manner that is in line with the needed control measures. In SR-75 road, there are a number of good points where diversion points can be employed to assist in the mitigation of the traffic challenges. Comprehensively, the best measure requires that necessary protocols are followed in the diversion. All the motorists who might be interested or obliged to follow the road with tunnel may be diverted to the other roads to assist in the mitigation of challenges and comprehensively employing the best measures to assist in the reduction of challenges (Hamada et al., 2017). Based on the challenges, it is good to follow a quality control technique and ensure that road users have the best mechanism and reduce the inconveniences.

Diversion signage is useful in issuing the necessary instructions and reducing the complexity of the traffic. As a traffic control mechanism, it is good to identify the needed control measure requires that the vehicles follow the right paths and avoid the challenges of the same. Strategically, it is good to follow a comprehensive measure and ensure that the control mechanism is implemented as needed. The diversion signs are necessary for the control of traffic

and ensure that the right trucks are allowed into the intersection tunnel during the construction process.

3.4.3 Flexible orange reflective soft PVC Traffic cones

In modern construction, there is a need to employ flexible PVC cones along with the traffic. As a significant signal showing a construction is going on, the cones are useful, and it is necessary to follow the instructions that lead to safer avenues (Hamada et al., 2017). Signals of construction must be adhered to comprehensively to assist in the mitigation of challenges and control of the traffic as needed. Some of the necessary flexibility PVC traffic cones are used in variable circumstances and assist in the mitigation of challenges and the promotion of competent approaches as needed. Necessarily, the S-75 road will have the cones erected as needed to control the traffic each time such is needed.

3.4.4 Traffic safety ABS ceramic studs

In a bid to control the traffic in the S-75 road in Coronado, the safety AMS ceramic studs are employed to assist in strategic control and mitigation of the traffic congestion along the street. As an alarm that controls the flow of traffic, the studs will be used in controlling the traffic and implementing effective measures to assist in the effective and necessary control of the traffic. All the motorists who are designated to cross the road are effectively diverted to the necessary areas and promote a quality approach as needed (Zhang & Gambatese, 2017). In a comprehensive approach, it is good to follow the best ideas and ensure that fundamental approaches are implemented to control the traffic. The studs stand a good chance of good direction of the road users to follow the right paths as needed.

3.4.5 Flashlight solar-powered traffic road studs

Motorists are often misguided during dusk and may be tempted to cross the S-75 road irrespective of the ongoing project. The flashlight studs can be employed on the roads to assist in a quality process and ensure that basic interventions are applied for the promotion of a better and competent strategy as needed (Zhang & Gambatese, 2017). The best and quality measure applied in the control of the challenge ensures that the policy is effectively implemented to assist in the mitigation of the adversity and ensure that a safety measure is implemented in the control of the negative consequences associated with the same. Traffic studs are necessary for the control of challenges and effective approach implementation as needed to protect and ensure that better and effective strategies are applied as needed (Kanai, Katou & Hamada, 2019). The stud flashlights

have the capability to operate the whole night and give directions where necessary for strategic control and policy implementation as required.

3.4.6 Billboard signage

As signage, the billboards are useful in the promotion of a competent and effective traffic control measure. At a far distance, the traffic can be controlled by having a bigger picture of the project for the motorists to consider some alternative routes (Kanai, Katou & Hamada, 2019). Early planning of the routes is necessary in the promotion of better measures of curbing the traffic congestion and other inconveniences associated with the same. The pictures captured in the billboards are supposed to reflect on the true nature of the project and facilitate the process as necessary.

3.5 Temporary Concrete Barriers to Control Traffic

Concrete serves as a good reinforcement barrier to control traffic and ensure that better mechanisms are applied as needed. SR-75 road will be intercepted by the pedestrian tunnel and therefore control traffic (Zhang & Gambatese, 2017). Motorists such as vehicles must adhere to the traffic rules and focus on the implementation of best practices to ensure that better and effective traffic control is applied. Significantly, there is a need to use concrete walls in the areas that are necessary to assist the construction in the proceeding.

The concrete barriers are good for quality and effective control of the traffic to ensure that better measures are applied as needed. SR-75 road is a bog traffic road, and the lane is vast; hence the construction process must adhere to all the rules of construction. To facilitate better construction protocols, traffic control requires that temporary barriers are laid to assist in allowing the project to proceed effectively and uninterrupted. Strategic interventions are good in effective and quality control approaches as needed. The barriers are good and facilitate a quality protocol to ensure that effective reinforcement is applied as necessary (Zhang & Gambatese, 2017). Strategically, a needed protocol is required in a supplemental process to assist in the mitigation of challenges as necessary.

There are stages in the tunnel construction, and the most important one is TBM jack and bore drilling (Kanai, Katou & Hamada, 2019). The process requires that the road is left untraveled to assist in the effective mitigation of the challenges and control of adversities. There is a need to follow a good protocol in the elimination of adversities and a comprehensive approach to the reduction of adversities as needed. A good policy is necessary for the control of measures as

needed. Based on the challenges, it is good to follow a good policy and ensure that quality aspects are considered as needed. Some of the necessary approaches in the mitigation of challenges require that the concrete wall is constructed, and the motorists barred from accessing the road.

The concretes can be placed on specific lanes to assist in allowing an only specific number of road users to pass through (Kanai, Katou & Hamada, 2019). Better strategies in control are necessary for mitigating the challenges and promoting a competent pass-through process, which is effective. Regulatory techniques are good in reinforcement and reduction of negative issues for quality and better measures as needed (Zhang & Gambatese, 2017). With the aid of the officers, it is good to assist the road users to come up with good plans of crossing, especially in the areas where the tunnel has not been drilled. The workers at the site require peace, and the motorist is supposed to be limited from passing through the tunnel to assist in the mitigation of challenges and control any form of adversity as recommended.

3.6 Sidewalk Access for Limited Road Users

Traffic control is a strategy to limit the challenges and promote a competent and effective strategy in the elimination of challenges as well. Necessarily, the SR-75 road requires a comprehensive and good measure in mitigation of challenges associated with overcrowding and unplanned crossing as needed (Kanai, Katou & Hamada, 2019). The best technique requires that implemented policies are applied for mitigation of challenges and promotion of a competent and better measure as needed. Selectivity in access is a good approach to assist in allowing only legitimate and less-stressful traffic users to have access.

All the roads and avenues cannot accommodate the traffic users, such as cyclists and other pedestrians. After basic processes of the tunnel construction such as DBM jack and bore drilling, the pedestrians and cyclists can be allowed across the tunnel to assist in the mitigation of the challenges and promotion of competent and necessary interventions as needed (Kanai, Katou & Hamada, 2019). A good policy as needed is to necessitate a good policy and ensure that competent approaches as needed. The bore drilling only covers the bigger aspect of SR-75 road, and the sidewalks can be allowed to be used by the pedestrians. There are individuals who must be allowed to pass through the area and allow a competent and effective strategy in the construction process.

Total prohibition of movement along the SR-75 road would be senseless, but some degree of control can work to effectively assist in the mitigation of the challenges and promotion of commitment as needed (Zhang & Gambatese, 2017). A good policy is necessary for necessary implementations to assist in the control of challenges and the promotion of better aspects as needed. A good policy should be reinforced in the sidewalk to assist in the partial allowance of the pedestrians for three months to assist in the promotion of necessary strategies of access as needed (Kanai, Katou & Hamada, 2019). Necessarily, it is needful to ensure that good and effective measures are applied in an integrated manner to perfectly control traffic and ensure that quality measurements are applied as necessary. Some of the challenges require a prompt solution to manage the traffic.

Heavy-duty traffic vehicles can damage the road and the tunnel in construction, and therefore a prohibited traffic flow on the surface of the tunnel is necessary mitigating the risks associated with the tones of a load (Kanai, Katou & Hamada, 2019). Setting aside sidewalks is a discriminative measure to assist in the control of the adversity and ensure that the challenge is comprehensively mitigated. Strategically, the waking space is set aside for cyclists and pedestrians to continue walking for three months. After construction of the pedestrian tunnel, it is good to give it time to dry up and ensure that integrity is assured. Restricted traffic is possible through banning of driving or any traffic along the road. The sidewalk should be made precisely for the specific users of the road to ensure that they have a specific routine.

There are guidelines for specifying the traffic control measures, and they include an implementation of a strategy to limit the adversity and control any form of negativity (Kanai, Katou & Hamada, 2019). Based on the applied principles of management, it is necessary to follow a comprehensive approach and focus on the policies that are crucial for limited access to the S-75 road. The sidewalks are good for usage as long as the construction threshold duration is met to meet the stability level. A good measure in promoting a competent approach is by applying the guidelines in a better way to promote a good policy as needed (Zhang & Gambatese, 2017). Once the concrete and constructed tunnel have gained the necessary strength, it becomes a good strategy to assist in the control of the challenges and effective mitigation that is necessary for identifying the necessary and basic control measures for a quality approach necessary for better strategies as needed. The applied control will not only be effective from the construction hours of 8:00 p.m. to 5:00 a.m. but all the time during the designated period.

3.7 A street Detours control system

Emergency banning of traffic along the street of SR-75 road is another good strategy to assist in the mitigation of the challenges by focusing on implemented approaches to reduce the heavy traffic in the section (Zhang & Gambatese, 2017). There are a number of challenges associated with working while allowing the traffic to flow even at a controlled level along the street.

Effective measures are recommended in assisting to control the challenge and recommend better and effective measures as needed. The best intervention requires that necessary approaches are applied in mitigation of challenges. Some of the fundamental and core measures require that effective approaches are implemented in the control of negative issues with the traffic.

Street detours are good strategies that the Coronado Municipal in San Diego can apply to reduce the level of access to the street. Peaceful construction times are required by the engineers to execute and deliver a quality project. The banning should be announced prior to assist in readjustments and ensure that competent strategies are followed for mitigation of problems.

Quality interventions are required in assisting the workers have a quality and peaceful time. The tunnel requires a comprehensive control strategy whereby effective and essential techniques are applied in the control of the adversities as needed.

Detours serve to eliminate chances of negativity and other issues that limit the positive aspects as required (Zhang & Gambatese, 2017). The traffic control mechanism can work as long as the measures can be implemented to control the adversity. Strategically, detours are meant to totally eliminate the traffic, which is healthy for the construction of the pedestrian tunnel to be completed. With implemented rules, it comes to be a perfect approach in the reduction of challenges and control of negativity, which is assistive in the regulation of negative outcomes of construction demands (Hamada et al., 2017). With the motorist having the information on temporary banning of the SR-75 road, it will be easier to manage traffic in other free avenues so that the imitated work can proceed at the required speed.

Detours as a strategy require other supportive planning mechanisms to assist in the reduction of the confusion (Zhang & Gambatese, 2017). Along other streets, there are proposed bus stops that are supposed to be used, especially near the crossroads. A comprehensive strategy is necessary for controlling traffic and supporting and effective intervention that is useful in mitigation of challenges as needed. Alternative routes must, therefore, be followed to assist in cooperative mechanisms and reduction of adverse effects associated with the identified traffics. Good control

strategies are required in the effective measurement techniques to support the ideas and promote a good strategy for better approaches as needed (Zhang & Gambatese, 2017). The notice can be given through trusted channels such as radio and television to promote competent and quality delivery and broadcast to various involved parties.

3.8 Use of flaggers to control traffic

Along the SR-75, flaggers can be applied to assist in the reduction of traffic in the areas.

Flaggers serve as competent strategies to assist in the regulation of traffic that requires control measures. San Diego municipality is in a position to assist in the reduction of the cases of traffic and issuing a warning of the construction projects that are necessary.

Road flaggers have been proven effective in the mitigation of traffic congestion since they convey a special message of access (Lu & Zhao, 2018). Some of the necessary interventions require that the flaggers are identified, and decorations made to promote good control of the traffic. Creating awareness of the necessary traffic rules to be followed across the Tarawa Road is necessary. There are incidences whereby the assurance of traffic control is created to promote a qualitative approach and ensure that the vehicles divert (Saha & Sisiopiku, 2020). A real awareness of the construction is possible when the flaggers are used to warn the motorists of the impending inconvenience so that they can ensure that quality approaches are implemented in the reduction of the traffic flow along the streets.

Flaggers are necessary to assist in precise traffic control by targeting specific motorists. Along the streets, the intersection of the tunnel should be protected (Kanai, Katou & Hamada, 2019). Flaggers serve a good purpose and an indicator to the motorists that there is a need to focus on the better aspects of the road (Ram & Smith, 2017). The flaggers are easily noticed, and as a choice of traffic control, it can be considered as another effective mechanism to deal with the challenge of overwhelming traffic.

3.9 Temporary shifts of the lane for controlling traffic

Along SR-75 road, there is a great barrier associated with the drilling and bores creating to accomplish the mission of constructing a tunnel. As a significant factor in the mitigation of the challenges, it is necessary to identify a god lane whereby temporary passages can be used by specific and selected motorists.

The lane shifts that are good in the control of traffic may also be in the form of portage whereby the users ensure that pedestrians dislodge and move around the construction without going

through the construction project (He, Salem & Salman, 2017). Strategic measures are necessary for the control of traffic, and therefore portage can assist in precise control that is useful in the elimination of challenges and qualitative approaches that ensure that necessary strategies are applied for mitigation of the traffic flow along the road (Hamada et al., 2017). There are policies that should be implemented by the San Diego government to assist in promoting the construction project so that it can work out and promote a competent approach as required.

3.10 Conclusion

Traffic control along SR-75 road is one of the major aspects of ensuring that a successful strategy is applied in the mitigation of challenges of construction. For a successful construction of the pedestrian tunnel, a myriad of strategies must be implemented to assist in the reduction of challenges and the promotion of a necessary strategy to reduce the negativity and other associated challenges. Some of the control strategies are useful in the promotion of a good control approach and ensure that competent policies are implemented to ensure that better control measures are applied in road traffic control. With the effective application of traffic control, the measures can be good and possible in the mitigation of traffic-related inconveniences. San Diego requires some control of the traffic along the road during the construction period to assist in overcoming the challenges and ensure that competent and effective approaches as needed.



Appendix 4: Structural Design Report

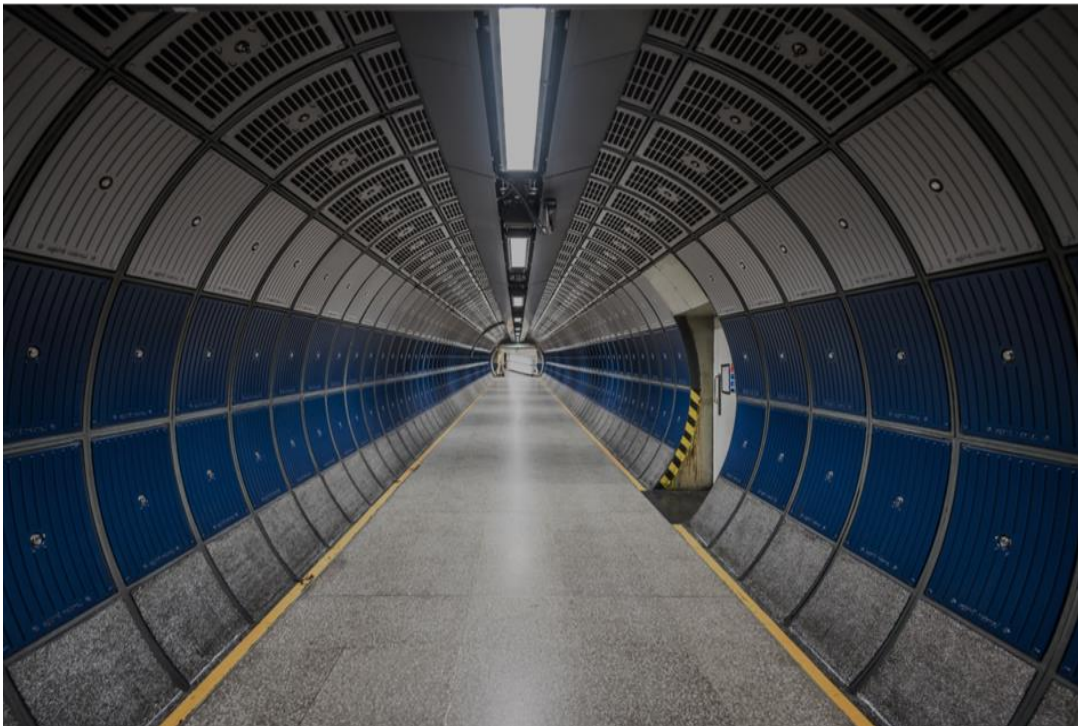

Coronado NAB Pedestrian Tunnel

Final Design Submittal by Civil Creations Inc.

Team 22

May 6th, 2020

Table of Contents

Appendix 4: Structural Design

4.1 Purpose	51
4.2 Notation and Symbols	52
4.3 Structural Discussion	53
4.3.1 Introduction	53
4.4 Tunnel Detail	53
4.5 Structural Loads	54
4.5.1 Dead Load/ Vertical Pressure	54
4.5.2 Live Load	55
4.5.3 Earth Load and Ground Water Pressure	55
4.5.4 Bearing Pressure	56
4.5.5 Side Pressure	57
4.5.6 Internal Pressure	58
4.6 Analysis Procedure and Results	58
4.6.1 Structural Recommendation	58
4.6.2 Moment and Shear Resistance	59
4.6.3 Rebar Determination	62
4.6.4 Bent Bar Schedule	63
4.7 Temporary Structural	64
4.7.1 Shoring	64
4.7.2 Sheet Piles	66
4.7.3 Waler	66
4.7.4 Strut	67
4.7.5 Formwork	67
4.8 Conclusion and Recommendation	68
4.9 Design Codes	69

List of Figure:

Figure 4-9: Tunnel Cross Sectional	51
Figure 4-10: Outer and Inner Radius	53
Figure 4-11: The Impact of Live Load	55
Figure 4-12: Impact of Bearing Pressure	57
Figure 4-13: Side Pressure	58
Figure 4-14: Shoring System Component	64
Figure 4-15: Sheet pile with Strut and Waler System	65
Figure 4-16: Z-Shaped Hot Rolled Sheet Piles	65
Figure 4-17: Strut Spacing	66
Figure 4-18: Formwork	68
Figure 4-19: Overall of the Tunnel	69

List of Tables:

Table 4-4: Bar Bending Schedule.....	63
---	-----------

Appendix 4: Structural Design

4.1 Purpose

The purpose of this report is to estimate the demand of Coronado NAB Pedestrian Tunnel and consider the procedures it will be used for the structural design. This report will include design loads, structural recommendation, and provide design Codes. To represents a vertical plane cut through the tunnel. The tunnel cross section as shown in **Figure 9** shows the tunnel's height and width along with alternative ceiling slab.

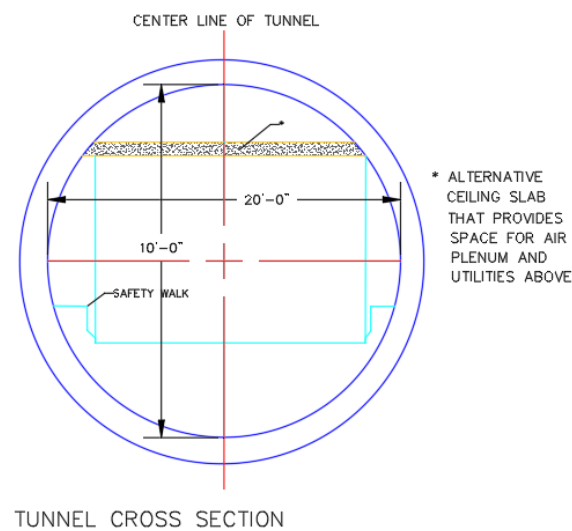

Figure 9: Tunnel Cross Section

Design load is a combination of dead load, live load, and earth load. Dead load is determined by calculating the surface asphalt and surface concrete. The live load determined by the weight of cars and the weight of the people inside cars that it will pass above the tunnel. The Earth load is determined by finding horizontal diameter of the tunnel and total unit weight of the soil.

Structural recommendation has been determined by detailed calculations for concrete, steel rebars, ground water pressure and provided it to the construction team of the tunnel. To assure if the structural recommendation is without any mistakes, we accordance it to the ASCE Manual.

Civil creations Inc. will perform the structural design work and design calculations based on design codes according to AASHTO, LRFD design specifications, ASCE Manual, Caltrans amendments, Caltrans Seismic Design.

4.2 Notation and Symbols

Description	Symbol (S)
Concrete	$f'_c = 4.0$ ksi
Reinforcing Steel	$f_y = 60.0$ ksi $E_s = 29,000$
Wall thickness	$t_{wall} = 12$ inches
Top Slab Thickness	$t_{is} = 16$ inches
Haunch Size	$dim_{haunch} = 12$ inches
Width of walkway	$W_{walkway} = 20$ feet
Height of wall	$h_{wall} = 10$ ft
Strip Width	$W_{strip} = 1.00$ ft
Normal weight of reinforced concrete	$W_c = 0.150$ kcf
Section height of Top Slab	$h = 16.00$ inches
Section width of Top Slab	$b = 12.00$ inches
Clear distance to rebar from tension face	$c_{1c} = 1.00$ inch
Area of single Rebar	$A_{s-bar} = 0.60$ in ²
Diameter of rebar	$dia_{bar} = 0.875$ in
Spacing of rebar	$s = 6$ inches
Unit Weight of soil	$\gamma = 20$ KN/m ³
Depth of the tunnel	$H = 22$ ft
Coefficient of horizontal effective stress	$K = 0.8$ (Assumed for Dense Sand)
<i>the coefficient of pressure for tunnel linear</i>	c_d
Active pressure at any given depth	P_a
Active Soil Coefficient	K_a
$\beta_1 = 0.85$ if $f'_c \leq 4.0$ ksi	

4.3 Structural Discussion:

4.3.1 Introduction:

The designed tunnel is to replace the pedestrian cross Caltrans SR-75 at the existing traffic signal at Tarawa Road with the existing at-grade pedestrian crossing with a safe pedestrian-friendly tunnel under SR-75. This pedestrian tunnel is to connect both sides of NAB under CaltransSR-75 to assure safety for the pedestrians. The circle tunnel consists of Alkali Concrete walls that it will be reinforced with steel bars as shown in **Figure10** . For the foundation, driven concrete piles, and steel will be used to make the foundation stronger.

4.4 Tunnel Detail

The designed tunnel has the following detail:

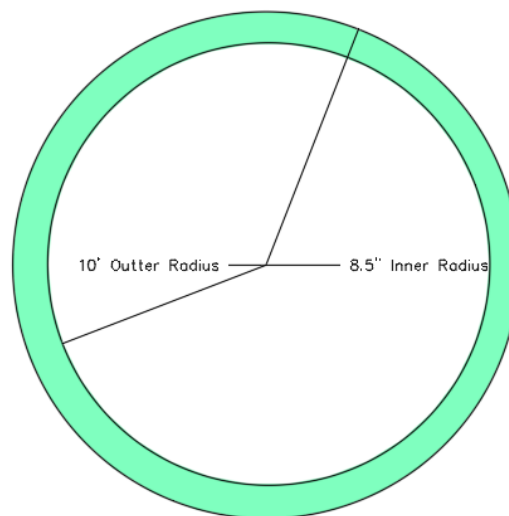

Figure 10: Outer and Inner Radius

Where:

Ro = outer radius of the tunnel = 10 feet

Ri = inner radius of the tunnel = 8.5 feet

The tunnel spans a length of 140 feet from end to end.

4.5 Structural Loads:

In this section, structural loads will be considered for the underground tunnel. The loads that it will be applied for the tunnel; live. Dead, and earth load. For clarity, a 1 foot strip considered for the load computation. The total load calculated and found 15,431.25 *ib – ft*.

$$\begin{aligned} \text{Total Load} &= \Delta D + \Delta l + p_d \\ &= 7991.25 + 6000 + 1440 = 15,431.25 \text{ } ib - ft \end{aligned}$$

4.5.1 Dead Load/ Vertical Pressure

Dead load is the load that is directed to the tunnel. The loads that are considered for the dead load are; asphalt surface and surface concrete. To find the surface asphalt, we need to find the volume of the asphalt and the dense. For the concrete surface, we need to find the volume of the concrete surface and the dense. The vertical pressure also considered since there is a pressure that is affecting the upper and lower of the tunnel.

$$\text{Dead Load} = \Delta D$$

$$\Delta D = \text{surface asphalt} + \text{surface concrete}$$

$$\text{Volume Asphalt Surface} = L * B * T$$

$$= (108/12) * (20/12) * 0.5 = 20.875 \text{ } ft^3$$

$$\text{Asphalt surface} = \text{Volume Asphalt Surface} * \text{dense}$$

$$\text{Asphalt Surface} = 20.875 * 164 = 3423.5 \text{ } ib - ft$$

$$\Delta D = 1.2 * 3026.875 = 3632.25 \text{ } ib - ft$$

$$\text{Volume Concrete Surface} = L * B * T$$

$$= (108/12) * (20/12) * 0.5 = 20.875 \text{ } ft^3$$

$$\text{Concrete Surface} = \text{Volume concrete surface} * \text{dense}$$

$$\text{Concrete Surface} = 20.875 * 145 = 3026.875 \text{ } ib - ft$$

$$\Delta D = 1.2 * (3026.875 + 3632.5) = 7991.25 \text{ } ib - ft$$

According to ASCE:

The vertical pressure on the tunnel lining in both of upper and lower of the tunnel:

$$\sigma_v = \gamma H$$

$$\sigma_v = 20 * 22 = 440 \text{ } \text{Kpa.}$$

The Horizontal pressure on the sides of the tunnel:

$$\sigma_h = K \sigma_v$$

$$\sigma_h = 0.8 * 440 = 352 \text{ } \text{Kpa.}$$

4.5.2 Live Load

Live load is determined by assumption of weight of car, and maximum people in one car, that is passes above the tunnel as shown in **Figure 11**. The total live load calculated is 6000 lb-ft. For stresses and internal load, it converted to pressure load.

LIVE LOAD PRESSURES

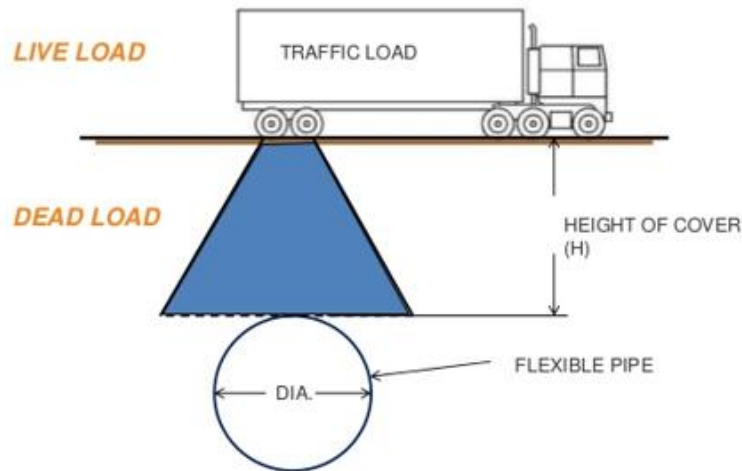

Figure 11: The impact of live load

$$\text{live load} = \Delta l$$

Assumed that the weight of the car is 3,000 lb

The maximum people in one car = 5 people

The average weight for one person is 150 lb

$$= 5 \cdot 150 = 750 \text{ lb}$$

$$= 750 + 3,000 = 3750 \text{ lb}$$

$$\text{live load} = \Delta l = 3750 \cdot 1.6 = 6000 \text{ lb} - \text{ft}$$

4.5.3 Earth load/ Ground Water Pressure

Earth load is determined by the total unit weight of the soil, the horizontal diameter of the tunnel, and the coefficient of the tunnel. The total earth load is $1440 \text{ ft}^2 - \text{pcf}$.

For the ground water pressure, it will be included in the earth load because the height of water surface above the top of tunnel is less than the result of multiplication of both of the coefficient pressure of the tunnel and horizontal diameter.

$$\text{Earth Load} = p_d = w * D * c_d$$

$c_d = \text{the coefficient of pressure for tunnel linear} = 0.90$

$w = \text{total unit weight of soil} = 120 \text{ kn/m}^3$

$D = \text{horizontal diameter of the tunnel} = 20 \text{ feet}$

$$p_d = 120 * 20 * 0.9 = 1440 \text{ ft}^2 - \text{pcf}$$

Ground Water Pressure:

$$p_w = \gamma * h_w - (D * c_d)$$

$\gamma = \text{unit weight of water} = 62.4 \text{ pcf}$

$h_w = \text{height of water surface above the top of the tunnel} = 10 \text{ ft}$

Since h_w is less than $(D * c_d)$. Ground water pressure is included in the evaluation with earth load, when the saturated unit weight is used.

$$h_w = 10 \text{ ft}$$

$$(D * c_d) = (20 * 0.9) = 18 \text{ ft}$$

4.5.4 Bearing Pressure

Bearing pressure as shown in **Figure 12** is the upward reaction of the soil to the tunnel, this is because of impact of the vertical pressure of the tunnel loads and the self-weight of the tunnel. For simplicity, is the contacting load between the tunnel and the soil under it. The allowable bearing pressure 2000 pounds per square foot.

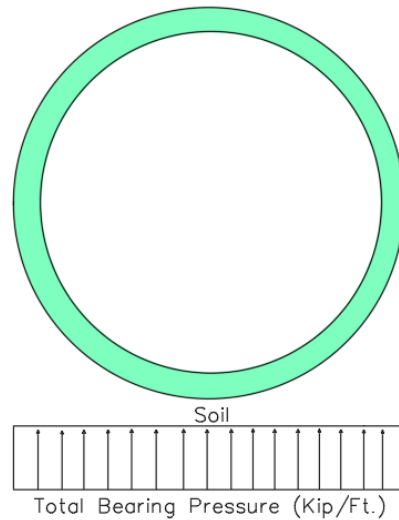

Figure12: Impact of Bearing Pressure

4.5.5 Side Pressure

The side pressure as shown in **Figure13** is the pressure that is impacting all the sides of the tunnel. For the horizontal side pressure is because the existing soil involved of both sides of the tunnel. The depth of the soil depends due to the increasing in the pressure, and from the diagram the horizontal side pressure takes almost a trapezoidal shape.

For the vertical side pressure is due to the total loads (dead load, live load, and earth load), vertical pressure, and the bearing pressure of the soil. This is for the top side. However, for the bottom side is the top side added to the soil that is between the top and bottom pressure and the density of the soil with taking in consideration the 1foot strip.

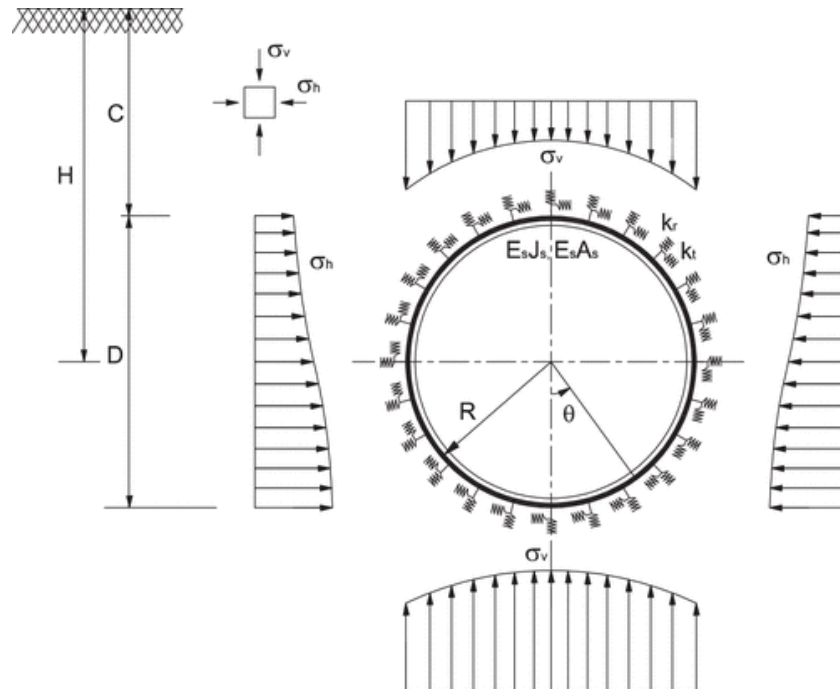

Figure13: Sides Pressure

4.5.6 Internal Pressure

Because of the tunnel is open or free at the end of both sides, we will consider it zero.

4.6 Analysis Procedure and Results

This section focuses on the procedure that is used to calculate the structural design.

Alkali selected the appropriate type of concrete, Cement type III Fly Ash. that it should be used to build the tunnel. Major design consideration must be given to the foundation to support the structure weight and induced stress from hydraulic presses.

4.6.1 Structural Recommendation

Structural recommendation design will be based on railing, floor slab, roof slab, and wall system. The Alkali reinforced concrete will be used to build the tunnel. Steel rebars will also be used for the tunnel. The floor slab calculated to be 2760 ft², and for the roof slab of the tunnel calculate to be 2760 ft². Wall system for the two sides is 3888 ft².

For Railing:

H=3feet

L=140 feet

=3*140 = 420 square feet.

For Floor Slab:

Width=20 feet

Length= 138 feet

Thickness= 12 inch

=20*138*12= 33120 square feet or 1227 cubic yard

Roof Slab:

=20*138*12= 33120 square feet or 1227 cubic yard.

Wall System:

=18*1*108= 1944 for one side

For two sides= 2*1944= 3888 square feet or 144 cubic yard.

4.6.2 Moment and Shear Resistance

Using the equations from ASCE, AASHTO LRFD, live load moments and shear resistance were calculated.

For Top Section:

Height h= 16.00 in

width b= 12.00 in

Clear distance from tension face to rebar clr= 2.00 in

Area of rebar A_{s-bar} = 0.60 in²

Diameter of rebar dia-bar= 0.875 in

Spacing of rebar s=6.00 in

$$As = \frac{As_{bar} * b}{s} = \frac{(0.60) * (12)}{6} = 1.20 \text{ in}^2$$

$$ds = h - \frac{dia \text{ bar}}{2} - clr$$

$$ds = 16.00 - \frac{0.875}{2} - 2.50 = 13.062 \text{ in}$$

$$c = \frac{As*fy}{\alpha*\beta*f'c*b}$$

$$c = \frac{(1.20)*(60)}{(0.85)*(0.85)(4.00)*(12.00)} = 2.08 \text{ in}$$

$$\alpha = \beta * c = \alpha = 0.85 * 2.08 = 1.76 \text{ in}$$

$$Mn_{top} = As * fy(ds - \frac{a}{2})$$

$$Mn_{top} = (1.20) * (60)(13.062 - \frac{1.76}{2}) = 877.0 \text{ Kip-in}$$

$$Mn_{bot} = As * fy(ds - \frac{a}{2}) = Mn_{bot} = 1.20 * 60(14.563 - \frac{1.76}{2}) = 985.0 \text{ Kip-in}$$

$$\epsilon t = \frac{0.003}{c} (ds-c) = \frac{0.003}{2.08} (13.062-2.08) = 0.016$$

$$\phi f = 0.90$$

$$Se = \frac{b*h^2}{6} = Se = \frac{12*16^2}{6} = 512.00 \text{ in}^2$$

$$Mcr = \gamma_3 * \gamma_1 * fy * Sc = Mcr = 0.67*1.6*0.480*512 = 263.5 \text{ Kip-in}$$

$$\phi f Mn_{bot} = 0.90 * 985 = 886.5 \text{ in-kip} = 73.875 \text{ ft-kip}$$

Since $\phi f Mn > Mcr$ the minimum reinforcement is satisfied.

Exterior sidewall at the top of center:

Height $h = 12.00 \text{ in}$

width $b = 12.00 \text{ in}$

Clear distance from tension face to rebar $clr = 2.00 \text{ in}$

Area of rebar $As_{bar} = 0.60 \text{ in}^2$

Diameter of rebar $dia_{bar} = 0.875 \text{ in}$

Spacing of rebar $s = 6.00 \text{ in}$

$$As = \frac{As_{bar}*b}{s} = \frac{(0.60)*(12)}{6} = 1.20 \text{ in}^2$$

$$ds = h - \frac{dia_{bar}}{2} - clr = ds = 12.00 - \frac{0.875}{2} - 2.50 = 9.562 \text{ in}$$

$$c = \frac{As*fy}{\alpha*\beta*f'c*b} = c = \frac{(1.20)*(60)}{(0.85)*(0.85)(4.00)*(12.00)} = 2.08 \text{ in}$$

$$\alpha = \beta * c = \alpha = 0.85 * 2.08 = 1.76 \text{ in}$$

Nominal Moment:

$$Mn_{wall1} = As * fy(ds - \frac{a}{2})$$

$$Mn_{wall1} = (1.20) * (60)(9.562 - \frac{1.76}{2}) = 625.0 \text{ Kip-in}$$

$$Mn_{wall1} = Mn_{wall2} = 625.0 \text{ in-kip} = 52.08 \text{ ft-kip}$$

$$\epsilon_t = \frac{0.003}{c} (ds-c) = \frac{0.003}{2.08} (9.562-2.08) = 0.011$$

$$\phi_f = 0.90$$

$$S_e = \frac{b \cdot h^2}{6} = S_e = \frac{12 \cdot 12^2}{6} = 288.00 \text{ in}^2$$

$$Mcr = \gamma_3 * \gamma_1 * f_y * S_c = Mcr = 0.67 * 1.6 * 0.480 * 288 = 148.2 \text{ Kip-in}$$

$$\phi_f Mn_{wall1} = 0.90 * 625 = 562.5 \text{ Kip-in}$$

$$Mn_{wall1} = Mn_{wall2}$$

Since $\phi_f Mn > Mcr$ the minimum reinforcement is satisfied.

Nominal Shear resistance:

Height $h = 16.00 \text{ in}$

width $b = 12.00 \text{ in}$

Clear distance from tension face to rebar $clr = 2.50 \text{ in}$

Area of rebar $As_{bar} = 0.60 \text{ in}^2$

Diameter of rebar $dia_{bar} = 0.875 \text{ in}$

Spacing of rebar $s = 6.00 \text{ in}$

$Av = 0$ because slab is included in the reinforcement

$$As = \frac{As_{bar} * b}{s} = \frac{(0.60) * (12)}{6} = 1.20 \text{ in}^2$$

$$ds = h - \frac{dia_{bar}}{2} - clr = ds = 16.00 - \frac{0.875}{2} - 2.50 = 13.062 \text{ in}$$

For top slab:

$$dv = \max(0.72 * h, 0.9 * de) = \max(0.72 * 16, 0.9 * 13.062) = 11.76 \text{ in}$$

β = by assumption will be equal to 2.0 because there is no applied axial tension force and no transverse reinforcement required.

$Vp = 0$ kip there is no prestress force applied.

Shear resistance for this section:

$$Vc = 0.0316 \beta \gamma \sqrt{f'c} b dv$$

$$Vc = 0.0316 * 2.0 * 1.0 * \sqrt{4.0} * 12 * 11.76 = 17.80 \text{ kip}$$

$$Vs = 0$$

$$Vn1 = 0.25 f'c b dv + Vp$$

$$Vn1 = 0.25 * 4 * 12 * 11.76 + 0 = 141.1 \text{ kip}$$

$$Vn2 = Vc + Vs + Vp$$

$$Vn2 = 17.80 + 0 + 0 = 17.80 \text{ kip}$$

$$Vn - sec2 = (Vn1, Vn2) = (141.1, 17.8) = 17.8 \text{ kip}$$

4.6.3 Rebar Determination

Since the tunnel will be installed underground with less tension and is expected less flexure. Along with rebar size and spacing requirements along with minimum area. Based on reinforced concrete beam design, rebar size design for tunnel was considered, which they are $f_y = 60$ ksi and $f'_c = 40$ ksi. The most suitable rebar size is rebar #12, with bar diameter 1.5 in, and minimum spacing 1 in.

4.6.4 BBS Bar Bending Schedule

BBS for Rectangular an tunnel section

S.No	Description	No. Of Bars	Cut Length (ft)	Total Length (ft)	Weight in Pounds (#12 @6.0075lb/ft)
Rectangular Culvert					
1	Roof Slab				
	Top Reinforcement				
	Top Main bars #7 @ 6" c/c	276	21.91	6047.16	36328.31
	Top Distribution bars #7 @ 6' c/c	41	150.5	6170.5	37069.28
	Bottom Reinforcement				
	Bottom Main bars #7 @ 6" c/c	276	20.33	5611.08	33708.56
	Bottom Distribution bars #7 @ 6' c/c	41	150.5	6170.5	37069.28
2	Floor Slab				
	Top Main bars #7 @ 6" c/c	276	20.83	5749.08	34537.60
	Top Distribution bars #7 @ 6' c/c	41	150	6150	36946.13
	Bottom Reinforcement				
	Bottom Main bars #7 @ 6" c/c	276	20.83	5749.08	34537.60
	Bottom Distribution bars #7 @ 6' c/c	41	150	6150	36946.13
3	Wall System (#7 @6" c/c)				
	Left wall				
	Exterior main bars	217	20	4340	26072.55
	Exterior distribution bars	36	120	4320	25952.40
	Interior main bars	217	18.666	4050.522	24333.51
	Interior Distribution Bars	32	120	3840	23068.80
	Dowels	217	5	1085	6518.14
	Right Wall				
	Exterior main bars	217	20	4340.00	26072.55
	Exterior distribution bars	36	120	4320.00	25952.40
	Interior main bars	217	18.666	4050.52	24333.51
	Interior Distribution Bars	32	120	3840.00	23068.80
4	Circular Tunnel #12 @6"				

c/c)				
Outer side reinforcement	126	150.5	18963.00	113920.22
Inner Side reinforcement	107	150.5	16103.50	96741.78

Table 4: Bar Bending Schedule.

4.7 Temporary Structure

4.7.1 Shoring

Excavation depth is 22 feet which allows us to use soldier beams with tiebacks to make direct contact to the soil which will result in bearing and side pressure. In **Figure 14** provides a shoring system component with two- pair strand tieback system that will be used for the project. The materials that make up these systems are usually high strength steel ranging in allowable stresses between 60 and 120 ksi.

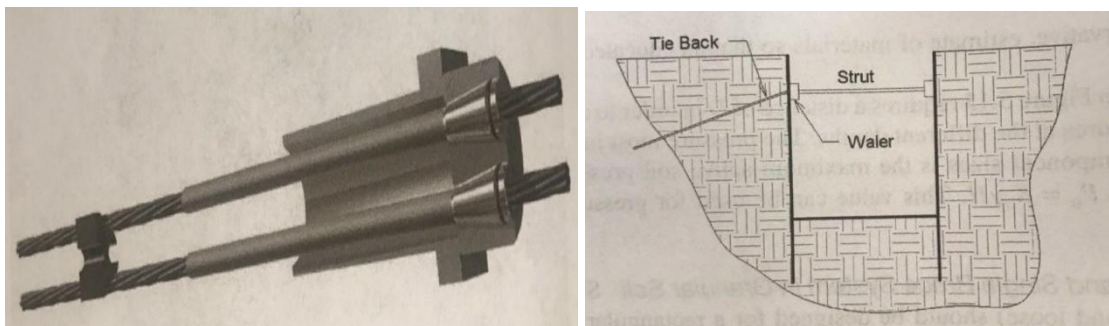

Figure 14: Shoring System Component

The system will be supported by sheet piles to avoid considerable settlement or bearing capacity failure of the soil. Struts and walers are used to support the sheet piles as shown in **Figure 15**.

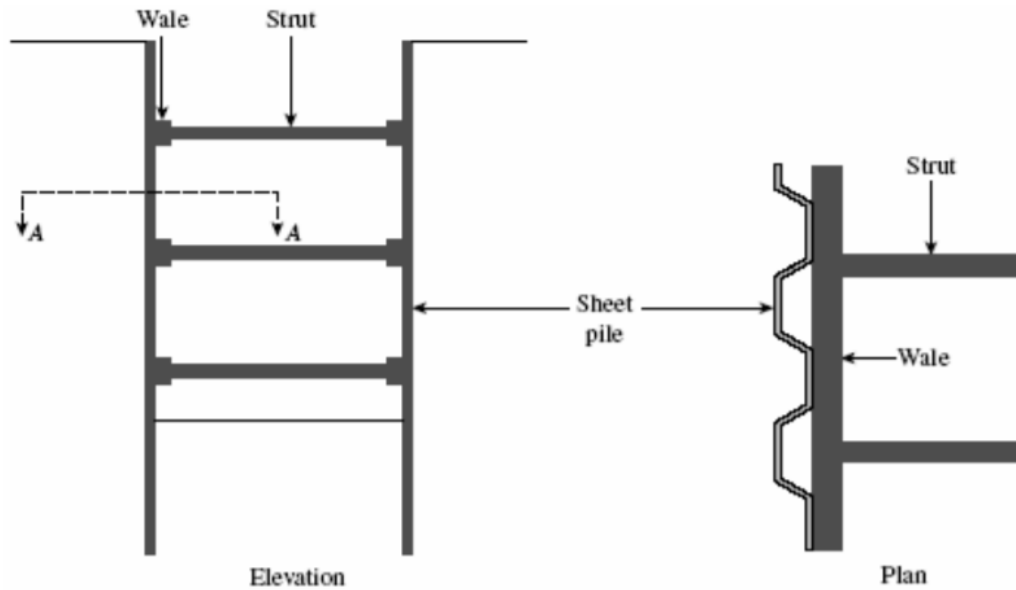

Figure 15: Sheet pile with strut and waler system

Using Z- shaped hot rolled sheet piles where the interlocks are shaped while the steel is formable as shown in **Figure16**. This makes the interlock tight, which means less water or soil can penetrate the interlock joint.



Figure 16: Z- shape hot rolled sheet pile

The lower hinge point is located at 3 feet below the bottom of excavation as shown in **Figure 17** along with horizontal strut spacing. Strut and waler are spaced at 17.5 feet on center with taking in consideration the size of the boring machine.

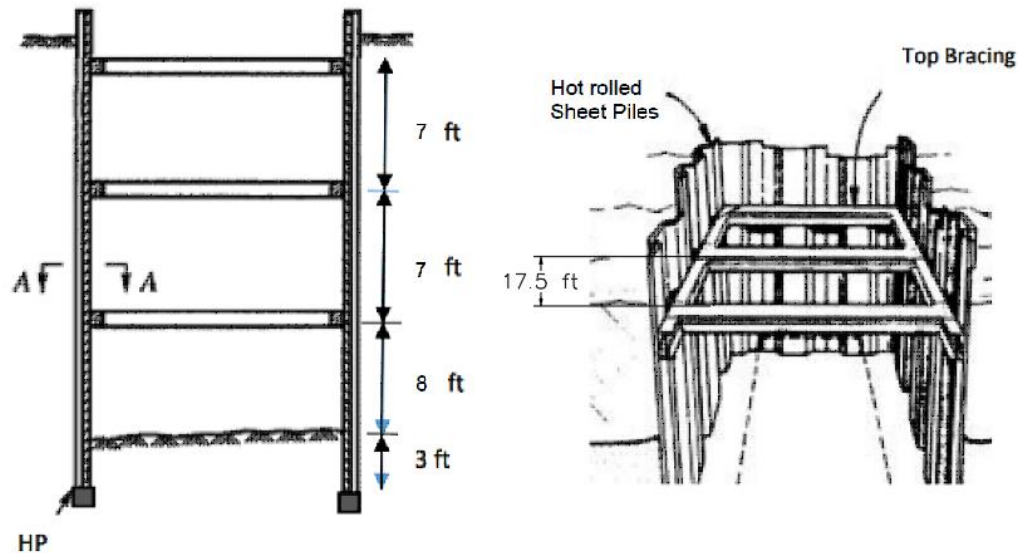

Figure17 : Strut spacing

4.7.2 Sheet Piles

Based on the Geotechnical report the maximum soil pressure is 1900 psf and the pressure is uniform across the height of the sheet pile wall.

$$L = 8' + 3' = 11\text{ft}$$

$$V_{max} = 0.6 wl$$

$$V_{max} = 0.6 \times 1.9 \text{ kips} \times 11 \text{ ft} = 12.54 \text{ Kips}$$

$$\text{Maximum moment} = \frac{wl^2}{10}$$

$$\text{Maximum moment} = \frac{1.9 \times (11)^2}{10} = 22.99 \text{ Kips. ft}$$

$$\text{Section modulus} = (22.99 \text{ kip.ft} \times 12 \text{ in/ft}) / 21.6 \text{ ksi} = 12.78 \text{ in}^3$$

From sheet pile (Skyline), we pick **AZ 12-700 S= 22.3 in³ most economical hot rolled sheet pile.**

4.7.3 Waler

As we are using A36 steel with an allowable bending stress of $F_b = 21.6$ Ksi. selecting the most economical W shape beam steps for the lower waler as follow

$$W = \text{Maximum pressure} \times \text{Tributary height} = 1.9 \text{ Kips} \times 7 + 112 = 17.1 \text{ Kips}$$

$$\text{Maximum moment} = wl^2 / 8 = \frac{17.1 \times (17.5)^2}{8} = 654.61 \text{ Kips. ft}$$

$$\text{Section modulus} = M_{\max} / F_b = \frac{654.61 \text{ kip.ft} \times 12 \text{ in/ft}}{21.6 \text{ ksi}} = \mathbf{363.67 \text{ in}^3}$$

From AISC steel beams manual

The **W24 x 146** with Section modulus of 371, it is the most safe and economical w shape to use for waler.

4.7.4 Strut

The strut can be designed for any system. The design of the strut is determined by axial load, unsupported length of the strut and the end connection.

For Coronado pedestrian tunnel project, the Strut length is 10 ft and it has 260-kip capacity, assume $k = 1.0$ and $r = 3$ inches which is the weak direction of gyration. Assuming 3 inches because this is an average of range of beams that are commonly used as struts.

$$SR = \frac{kl}{r} = \frac{1.0 \times 10 \times 12''}{3''} = 40$$

From AISC allowable buckling stresses for A36 ($F_b = 19.19$ ksi)

$$A (\text{Area}) = P \text{ capacity} \times F_b = 260 \text{ ksi} \times 19.19 \text{ ksi} = 13.55 \text{ in}^2$$

From AISC H pile (AISC) HP shape is HP12 x 87 ($r = 2.86$, $A = 15.5$)

$$SR = \frac{kl}{r} = \frac{1.0 \times 10 \times 12''}{2.86''} = 42$$

From AISC allowable buckling stresses for A36 ($F_b = 19.02$ ksi)

$$P_{\text{allowable}} = F_{bs} \times A = 19.02 \times 15.5 = 294.81 \text{ kips}$$

294.81 (P_{all}) > 260 (P_{act}) the strut works, since our Pallowable greater than Pact.

4.7.5 Formwork

Formwork is a temporary mold that is used to support the concrete poured into the molds. The best formwork for this project is Plywood for concrete. It is the most strong, efficient, and economic because it is the most repeated use once. One of the best advantages is providing a smooth finishing of concrete and it can be easily forming the

required size. The best size of plywood is 8'X 4" (2440 X 1220 MM), and the plywood grade is MR grade plywood that it is moisture resisting as shown in **Figure 18**.

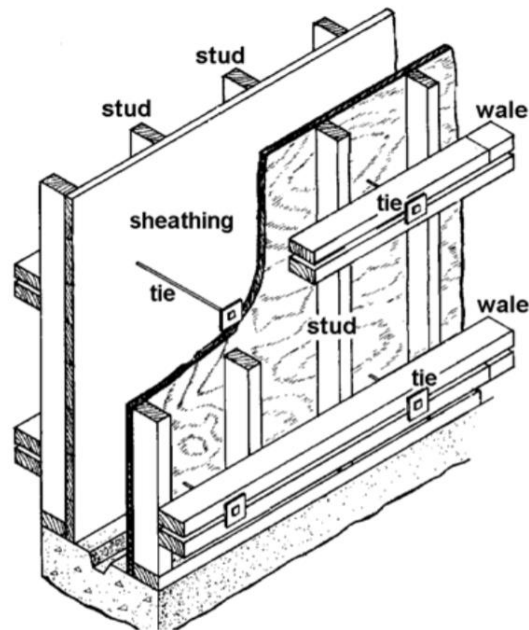

Figure18: Formwork

4.8 Conclusion and Recommendation

Based on the analysis and structural calculation for the designed tunnel in this report. A circular tunnel with outer radius 10 feet and inner radius 8.5 feet, a length of 140 feet. Type of concrete is Alkali concrete; it will be reinforced with #12 rebar (bar diameter = 1.5 inch) with spacing of 1 inch. The concrete of the underground tunnel can take a total load of 15,431.25 *ib – ft*. The wall system is 144 cubic yards for both sides, the roof and floor slab are 102 cubic yards respectively as shown in **Figure 19**.

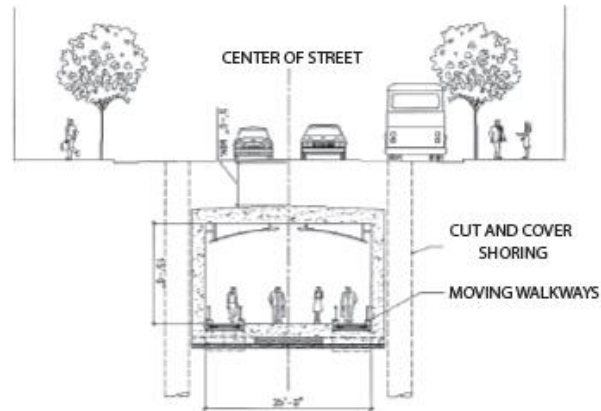

Figure 19: Over all the Tunnel

4.9 Design Codes

Caltrans

AASHTO LRFD

ASCE Manual



Appendix 5: Construction Management Report



Coronado NAB Pedestrian Tunnel Final Design Submittal by Civil Creations Inc.

Team 22

May 6th, 2020

Table of Contents

Appendix 5: Construction Management

5.1 Project Description.....	73
5.2 Summary of Site Attributes.....	73
5.2.1 Site Details.....	73
5.2.2 Hours of Work	74
5.2.3 Pre-start checks.....	74
5.3 Equipment Selection	74
5.3.1 EC350E Volvo excavator.....	75
5.3.2 Street Sweeper	75
5.3.3 Crane	76
5.3.4 Dump Trucks	76
5.3.5 Grader	77
5.3.6 Compactor	77
5.3.7 Tunnel Boring Machine	77
5.4 Site Logistic Plan	78
5.4.1 Security / Safety	78
5.4.2 Trucks Haul Routes.....	78
5.4.3 Office and Equipment Trailer.....	88
5.4.4 Parking.....	88
5.4.5 Laydown and Deliveries Area.....	88
5.4.6 Crane and Equipment Ways.....	89
5.4.7 Waste Management.....	89
5.4.8 Environmental Impact Protection.....	89

5.4.9 SWPPP and BMP's.....	89
5.5 Coordination Requirements	90
5.5.1 Personnel.....	91
5.5.2 Risk Assessments.....	91
5.6 Construction Material.....	91
5.7 Construction Phasing.....	93
5.7.1 Establish Budget.....	94
5.7.2 Preconstruction.....	94
5.7.3 Demolish.....	94
5.7.4 Earthwork.....	94
5.7.5 Structure.....	97
5.7.6 Interiors / Finishes.....	98
5.7.7 Electrical Works.....	98

List of Figures:

Figure 5.20 Site Layout	73
Figure 5.21 Excavator and Truck Loading Area... ..	75
Figure 5.22 Truck Production Cycle	76
Figure 5.23 Site Logistic Plan, West Side Truck Haul	79
Figure 5.24 Site Logistic Plan, East Side Truck Haul	85
Figure 5.25 SWPPP & BMPs	90
Figure 5.26 Components of Shield Machine	92
Figure 5.27 Tunnel Boring Machine	93
Figure 5.28 Demolish	95
Figure 5.29 Boring Machine Location	96
Figure 30: North Side Excavation	97

List of Tables

Table 5.5 Fill Factor	80
Table 5.6 Representative of Earth and Rock.....	81
Table 5.7 Fixed Cycle time for Loaders.....	82
Table 5.8 Rolling Resistance	83

Appendix 5: Construction Management.

5.1 Project Description

The site is located at Coronado Island in California. The construction site in question lies within a reasonable level terrain and on a stable ground.

The proposed site plan shown in **Figure 20** includes the proposed location of the pedestrian tunnel with access ramps and stairways. Boring machine location, work area, employees parking, laydown and deliveries area, office and equipment trailers. During construction and heavy machine operations, there will be one line blocked on the West side of the tunnel between Tarawa Road and Rendova Road.



Figure 20: Site Layout

5.2 Summary of Site Attributes

5.2.1 Site Details

1. Location: Coronado Island, Intersection Tarawa Rd and SR-75
2. Contract Type: Design Bid- Build

3. Final Project Cost: \$3,138,390.00
4. Architect: The Boring Company
5. Excavation Contractor: Precision Excavation and Demolition
6. Concrete Contractor: K&L Contracting, Inc.
7. Steel: Rossin Steel
8. Frames: Nevel
9. MEP: Baker electric
10. Demolition Contractor: Precision Excavation and Demolition
11. Project Managers (PM): Mina Ghareeb
12. Commencement Date: 06 July 2020
13. Completion Date: 16 January 2023

5.2.2 Hours of Work

The official work hours are as stipulated below but subject to pay overtime hours when the need arises:

Monday - Friday / 6:00 am - 2:30 pm

5.2.3 Pre-start checks

The construction works pre-start checks must cover the following key areas:

1. Availability of suitable plants and equipment to be used on site for specified works, based on the work schedule, ground stability and interruption of activities in case of adverse weather conditions.
2. Proximity hazards and safety risks in all relevant and designated areas.

5.3 Equipment Selection

The initial equipment selection is normally based on the size of the construction project and the overall development process. The key considerations during equipment selection are depth of excavations, production targets and the methods of construction. Noted is that the number and size of equipment were majorly calculated based on production rate and the project schedule.

5.3.1 EC350E Volvo excavator

The EC350E Excavator is a powerful production machine that is designed to increase productivity. It has a 3.5 bucket size and swing angle of 40°- 60°. Featuring a robust D13 Tier 4 Final engine, a new electro-hydraulic control system and Volvo's unique ECO mode, these heavy-duty excavators deliver up to 9% greater fuel efficiency. It's located on site layout as shown in **Figure 21** along with trucks loading area which that will give a better production and faster time to load.

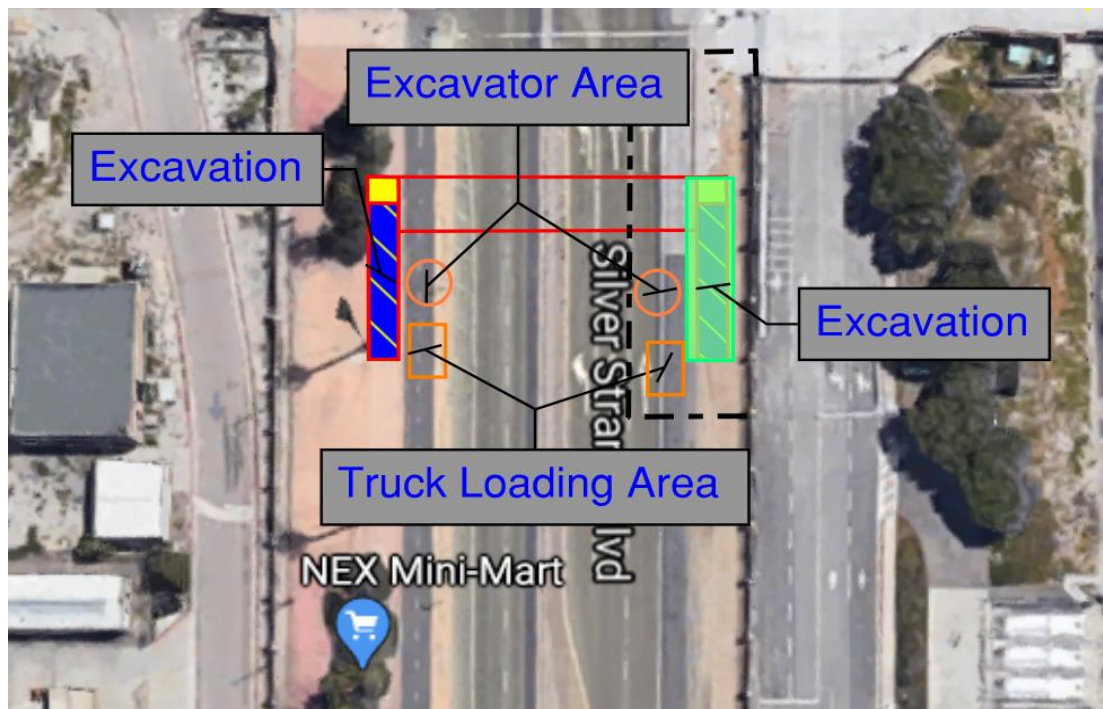

Figure 21: Excavator and Trucks Loading Area

5.3.2 Street sweeper

Tennant Sentinel Street Sweeper needed for construction projects because projects commonly produce huge amounts of dust and debris, which can be blown away or spilled over by trucks on the road around the site. Without regular cleanup, adjacent roads can be covered with dust and debris on a regular basis throughout the duration of the project.

5.3.3 Crane

The gantry crane is going to be used for this project which is specified for underground construction such as tunnels so that it can fit small areas. The crane capacity is 20-50 tons for material handling of tunnels. It is mainly employed to lift the cutter and shield plate of tunnel boring machines. The lifting mechanism of this gantry crane is rotatable for different digging directions. It is designed with safety instructions and an overload protection device system.

5.3.4 Dump Trucks

Dump trucks will have a 18 bucket size and will be required to complete one cycle of an activity in a production process as shown in **Figure 22**. Contractor goal is to move and haul as much material and in the shortest time possible. The cycle time for the amount of trucks a day will be an estimated certain number of trips as it will be calculated later in the report.

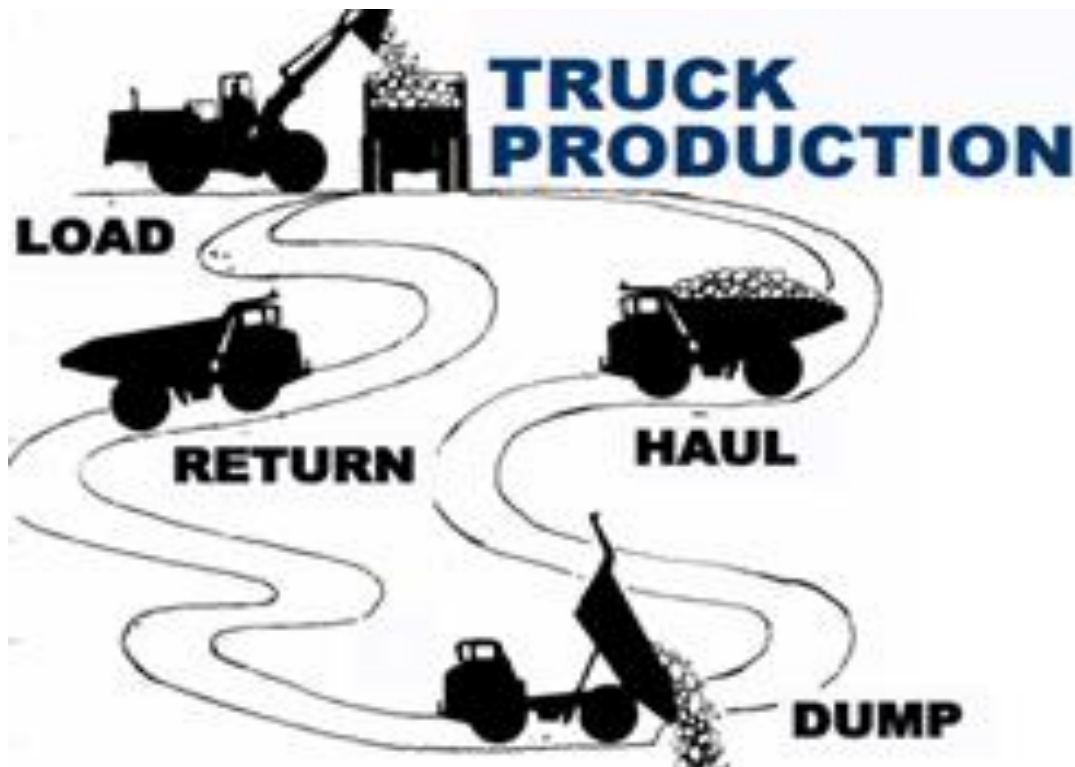

Figure 22: Truck Production Cycle

5.3.5 Grader

Grader used to create a flat surface during the grading process. The grader type that is going to be used on this project is articulated frame motor graders: These usually have both a front and rear axle. The blade is usually located somewhere between the two axles. The articulated frame graders are usually in small places where there is very less space to move and turnabout in.

5.3.6 Compactor

A normal plate compactor (slope compactor) is going to be used for the main volume of the backfill and a smaller compactor for the roof section, 15 t Volvo Backhoe loader. The same Volvo Backhoe loader is going to be used for placing the material on the layer with the help of a bucket loader and a leveler attached to the boom of the backhoe. The plate compactor is going to be attached to the same boom, requiring change of instruments between the different work stages. Whenever more space is needed, the loader is going to be driven away from the tunnel.

5.3.7 Tunnel Boring Machine

Bored tunnels are constructed with TBMs, which are shield systems led by drill bits mounted on a rotating cutter head that excavates a circular opening. These machines can be modified for use with varying ground types. The shape of nearly all TBM tunnels is circular. Earth Pressure Balance Machines (EPB) is going to be used for this project. It is used in soft ground with less than 7 bars of pressure. The cutter head does not use disc cutters only, but instead a combination of tungsten carbide cutting bits, carbide disc cutters, drag picks and/or hard rock disc cutters. Pressure is maintained in the cutter head by controlling the rate of extraction of spoil through the Archimedes screw and the advance rate. Additives such as bentonite, polymers and foam can be injected ahead of the face to increase the stability of the ground. We will be using this machine in order to build the tunnel without excavating the ground surface. The weight of EPB is going to be 30 tons.

5.4 Site Logistics Plan

5.4.1 Security / Safety

The perimeter fence is erected around the site to block passage and to prevent the view from buildings adjacent to the construction site.

Proper safety and warning signs are appropriately placed to serve as safety precautions. The signages are elected on designated points, along with the perimeter fence, and at the entry points.

5.4.2 Trucks Haul Routes

On the west side of the tunnel and during work hours of excavation, excavator and boring machine will take place, trucks will be going in cycles to load from the loading area and dump at the dump site. Dump site is located on the southwest side of the proposed tunnel location As shown in **Figure 23**. As calculated, approximately 2916 cy of soil taking out from the proposed tunnel location. The cycle time for each truck would be 8.61 minutes. Also, the truck cycle will include 4 buckets and 4 trucks for 418.12 Lcy as shown in calculations below.

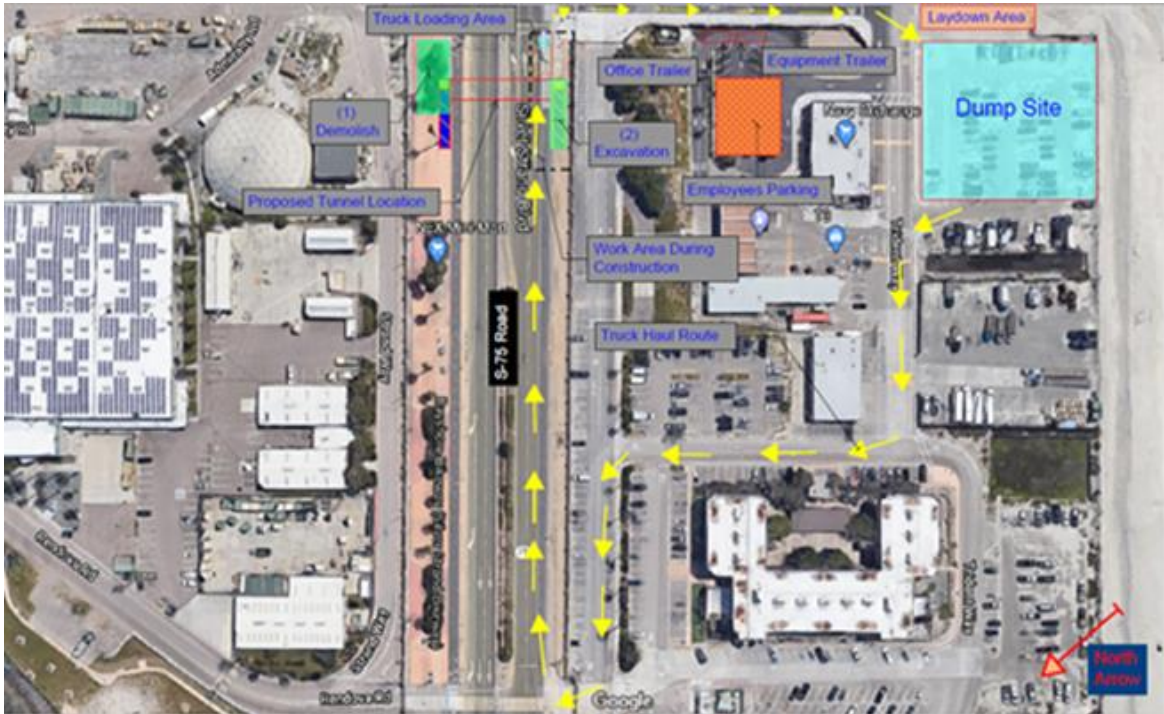

Figure 23: Site Logistic Plan; West side Truck Haul

Excavator bucket size: 3.5 cy

Excavator Swing Angle= 40°- 60°

Truck Bucket Load Capacity = 18 cy

Material type is Sandy Clay

Step 1: Bucket Load Weight

From **Table 5**, the fill factor for Sandy Clay material is 105%

Material	Fill factor* (%)
Moist loam/sandy clay	100-110
Sand and gravel	95-110
Rock—poorly blasted	40-50
Rock—well blasted	60-75
Hard, tough clay	80-90
*Percent of heaped bucket capacity.	
<i>Reprinted courtesy of Caterpillar, Inc.</i>	

 Export Data [EXPORT TO EXCEL](#)

Table 5: Fill Factor

Bucket Capacity= 3.5x 105%= 3.675 cy

$$Bucket\ Load = \frac{Truck\ Capacity}{Bucket\ Capacity} = \frac{18\ cy}{3.675} = 4.898$$

Due to some of the materials that could spill off during the load,

4 x Bucket Capacity

4 x 3.675 = **15 Lcy**

From **Table 6**, find the unit weight of Sandy Clay material

Material	Bank weight		Loose weight		Percent swell	Swell factor ⁺
	Ib/cy	kg/m ³	Ib/cy	kg/m ³		
Clay, dry	2,700	1,600	2,000	1,185	35	0.74
Clay, wet	3,000	1,780	2,200	1,305	35	0.74
Earth, dry	2,800	1,660	2,240	1,325	25	0.80
Earth, wet	3,200	1,895	2,580	1,528	25	0.80
Earth and gravel	3,200	1,895	2,600	1,575	20	0.83
Gravel, dry	2,800	1,660	2,490	1,475	12	0.89
Gravel, wet	3,400	2,020	2,980	1,765	14	0.88
Limestone	4,400	2,610	2,750	1,630	60	0.63
Rock, well blasted	4,200	2,490	2,640	1,565	60	0.63
Sand, dry	2,600	1,542	2,260	1,340	15	0.87
Sand, wet	2,700	1,600	2,360	1,400	15	0.87
Shale	3,500	2,075	2,480	1,470	40	0.71

*The swell factor is equal to the loose dry unit weight divided by the bank dry unit weight.

Table 6: Representative of Earth and Rock

$$\text{Load Weight} = 2200 \text{ lb/cy} \times 15 \text{ lcy} = 3300 \text{ lb}$$

$$\text{Load Weight} = \frac{33000 \text{ lb}}{2000 \text{ lbs/ tons}} = 16.5 \text{ Load weight which it will be Ok}$$

Step 2: Load Bucket Time

Table 7, to find the Wheel Loader cycle time

Loader size, heaped bucket capacity (cy)	Wheel loader cycle time* (sec)	Track loader cycle time* (sec)
1.00–3.75	27–30	15–21
4.00–5.50	30–33	—
6.00–7.00	33–36	—
14.00–23.00	36–42	—

*Includes load, maneuver with four reversals of direction (minimum travel), and dump.

Table 7: Fixed Cycle time for Loader

For Coronado pedestrian tunnel project, using Loader with heaped capacity varies between 4.00-5.00 cy

Based to **Table 7**, Wheel loader cycle time (sec) = **30-33 sec**

$$\text{Avg. wheel loader cycle time} = \frac{31.5}{60 \text{ min}} = 0.525 \text{ min}$$

Contractor decided to use 4 buckets x 0.525 min = **2.10 minutes for Loading time**

Step 3: Haul time

Total Resistance (TR) = Rolling Resistance (RR) + Grade Resistance (GR)

Table 8, to find the rolling resistance as it appears to be asphalt (50 - 60 lb./ton)

Type of surface	Steel tires, plain bearings		Crawler type track and wheel		Rubber tires, antifriction bearings			
	lb/ton	kg/m ton	lb/ton	kg/m ton	High pressure		Low pressure	
					lb/ton	kg/m ton	lb/ton	kg/m ton
Smooth concrete	40	20	55	27	35	18	45	23
Good asphalt	50-70	25-35	60-70	30-35	40-65	20-33	50-60	25-30
Earth, compacted and maintained	60-100	30-50	60-80	30-40	40-70	20-35	50-70	25-35
Earth, poorly maintained	100-150	50-75	80-110	40-55	100-140	50-70	70-100	35-50
Earth, rutted, muddy, no maintenance	200-250	100-125	140-180	70-90	180-220	90-110	150-200	75-100
Loose sand and gravel	280-320	140-160	160-200	80-100	260-290	130-145	220-260	110-130
Earth, very muddy, rutted, soft	350-400	175-200	200-240	100-120	300-400	150-200	280-340	140-170

*In pounds per U.S. ton or kilograms per metric ton of gross vehicle weight

Table 8: Rolling Resistance

$$Total\ Resistance = \left(\frac{(50 + 60)/2}{20\ lb/ton} \right) - 0 = 2.75\%$$

$$Truck\ Weight = \frac{36860\ lbs}{2000\ lb/tons} = 18.43\ tons$$

Total weight = Load weight + Truck Weight

Total weight = 16.5 + 18.43 = 34.93 tons

2.75% x 20 lb/ tone x 34.93 tone = 20 lbs

$$Truck\ Haul = \frac{0.096\ miles}{5\ mph} \times 60\ mints = 1.152\ minutes$$

$$\text{Truck Return time} = \frac{0.28 \text{ miles}}{5 \text{ mph}} \times 60 \text{ mints} = \mathbf{3.36 \text{ minutes}}$$

Rear dump trucks must be spotted at all times before dumping. Total dump time averages about 2 minutes.

West side Cycle Time Summary:

Load time	2.10 min
Haul time	1.152 mints
Return time	3.36 mints
Dump time	2 mints
Cycle time	8.61 minutes

$$\text{Trucks Production} = \frac{8.61 \text{ mints}}{2.10 \text{ mints}} = 4.1$$

$$\text{Trucks Production} = \frac{60 \text{ mints}}{\text{Truck Cycle}} \times \text{no. o Trucks} \times \text{Truck Volume}$$

$$\text{Trucks Production} = \frac{60 \text{ mints}}{8.61} \times 4 \times 15 \text{ lcy} = \mathbf{418.12 \text{ Lcy}}$$

$$\text{Trucks Production} = \frac{60 \text{ mints}}{8.61} \times 5 \times 15 \text{ lcy} = \mathbf{522.65 \text{ Lcy}}$$

4 Trucks	418.12 lcy
5 Trucks	522.65 lcy

As a result, the combination of bucket loads and trucks to provide the most economic operation would be **4 buckets** and **4 trucks** for **418.12 Lcy**.

When work begins on the other side of the Tunnel (East side), there will be another truck haul cycle going in rotation. Existing dump site is to Tarawa Road to stop at the loading area of the Tunnel. After loading, trucks will be making a left at Rendova Road to go back to dump at the dump site as shown in **Figure 24**. The cycle time for each truck would be 9.11 minutes. Also, the truck cycle will include 4 buckets and 4 trucks for 395.17 Lcy as shown in calculations below.

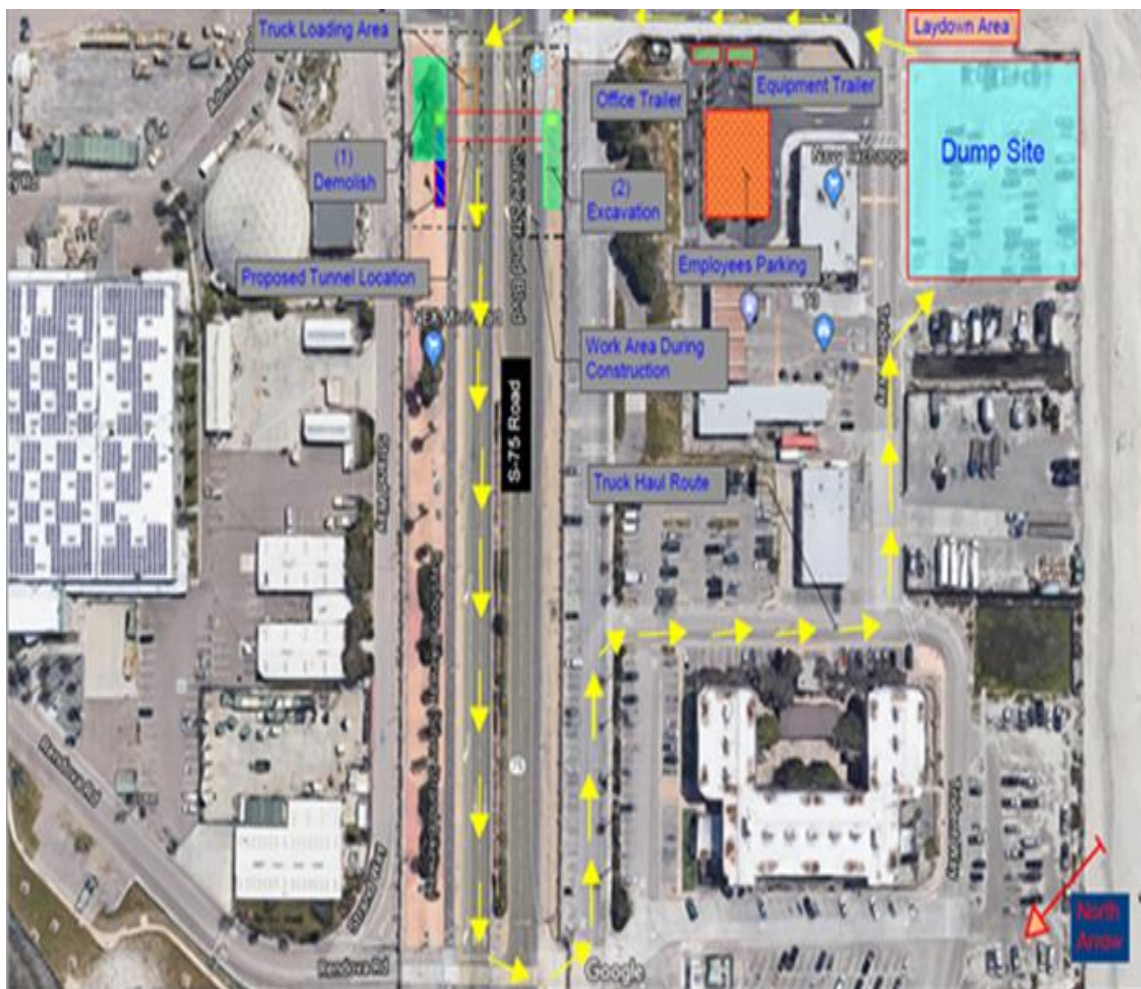

Figure 24: Site Logistic Plan; East side Truck Haul

Step 1: Bucket Load Weight

From **Table 5**, the fill factor for Sandy Clay material is 105%

Bucket Capacity= 3.5x 105%= 3.675 cy

$$\text{Bucket Load} = \frac{\text{Truck Capacity}}{\text{Bucket Capacity}} = \frac{18 \text{ cy}}{3.675} = 4.898$$

Due to some of the materials that could spill off during the load,

4 x Bucket Capacity

4 x 3.675 = **15 Lcy**

From **Table 6**, find the unit weight of Sandy Clay material

$$\text{Load Weight} = 2200 \text{ lb/cy} \times 15 \text{ lcy} = \frac{33000}{2000 \text{ lbs/ tons}} = 16.5 \text{ Load weight which it will be Ok}$$

Step 2: Load Bucket Time

Table 7, to find the Wheel Loader cycle time

For Coronado pedestrian tunnel project, using Loader with heaped capacity varies between 4.00-5.00 cy

Based to **Table 7**, Wheel loader cycle time (sec) = **30-33 sec**

$$\text{Avg. wheel loader cycle time} = \frac{31.5}{60 \text{ min}} = 0.525$$

Contractor decided to use 4 Buckets x 0.525= **2.10 minutes for Loading time**

Step 3: Haul time

Total Resistance (TR) = Rolling Resistance (RR) + Grade Resistance (GR)

Table 8 to find the rolling resistance as it appears to be asphalt (50 - 60 lb./ton)

$$Total\ Resistance = \left(\frac{(50 + 60)/2}{20\ lb/ton} \right) - 0 = 2.75\%$$

$$Truck\ Weight = \frac{36860\ lbs}{2000\ lb/tons} = 18.43\ tons$$

Total weight = Load weight + Truck Weight

Total weight = 16.5 + 18.43= 34.93 tons

2.75% x 20 lb./ tone x 34.93 = 20 lbs.

$$Truck\ Haul = \frac{0.303\ miles}{5\ mph} \times 60\ mints = \mathbf{3.64\ minutes}$$

$$Truck\ Return\ time = \frac{0.114\ miles}{5\ mph} \times 60\ mints = \mathbf{1.37\ minutes}$$

Rear dump trucks must be spotted at all times before dumping. Total dump time averages about 2 minutes.

East side Cycle Time Summary:

Load time	2.10 min
Haul time	3.64 mints

Return time	1.37 mints
Dump time	2 mints
Cycle time	9.11 minutes

$$\text{Trucks Production} = \frac{9.11 \text{ mints}}{2.10 \text{ mints}} = 4.3$$

$$\text{Trucks Production} = \frac{60 \text{ mints}}{\text{Truck Cycle}} \times \text{no. o Trucks} \times \text{Truck Volume}$$

$$\text{Trucks Production} = \frac{60 \text{ mints}}{9.11} \times 4 \text{ trucks} \times 15 \text{ lcy} = \mathbf{395.17 \text{ Lcy}}$$

$$\text{Trucks Production} = \frac{60 \text{ mints}}{9.11} \times 5 \text{ trucks} \times 15 \text{ lcy} = \mathbf{493.96 \text{ Lcy}}$$

4 Trucks	395.17 Lcy
5 Trucks	493.96 Lcy

As a result, the combination of bucket loads and trucks to provide the most economic operation would be **4 buckets** and **4 trucks** for **395.17 Lcy**.

5.4.3 Office and Equipment Trailers

The office and equipment trailer are temporary structures that serve as documentation and equipment storage rooms in addition to being avenues for site meetings.

5.4.4 Parking

Parking is located on the south west of the tunnel. It's near to the construction site which would give all workers the comfort and time to walk to the site.

5.4.5 Laydown and Deliveries Area

Required construction units and utility installation are delivered to site on approved articulated trucks and must be directed to designate loading areas by qualified assistants.

A grounds supervisor records every detail of deliveries on site including the type, number, and size of trunks together with the access requirements.

5.4.6 Crane & Equipment Ways

All crane and equipment movements must be authorized and are under the full control of the grounds site supervisor. They are all located within the job site area.

5.4.7 Waste Management

The site has a goal principle of general cleanliness for health and safety of employees, visitors and the community at large. Proper waste disposal practices are among the project's main objectives.

5.4.8 Environmental Impact protection

All activities associated with this site are typical to those of any construction site. Noise and dust pollution are minimized through blanket covering along the perimeter fence and street sweeper machine that goes around the site. The site is occasionally sprayed with water as required to minimize dust pollution.

5.4.9 Storm Water Pollution Protection (SWPPP) / Best Management Practices (BMPs)

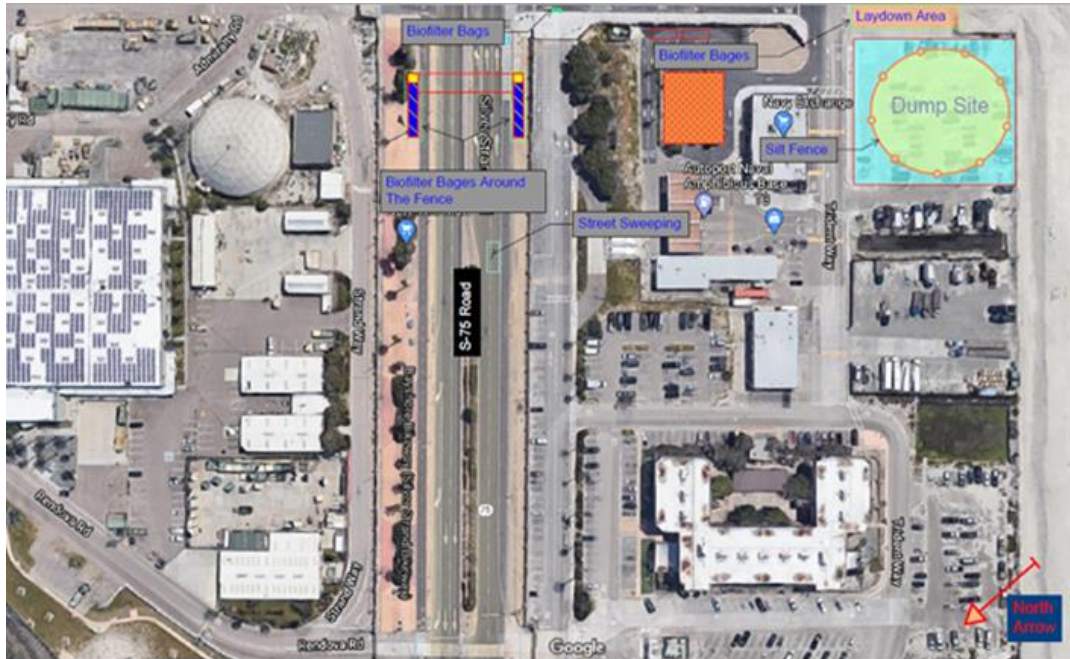

Figure 25: SWPPP & BMP's

- **Silt Fence**

The Silt Fence as shown in **Figure 25** is a temporary sediment control device that will go around the dump site to protect water quality in nearby the site from sediment in stormwater runoff.

- **Biofilter Bags**

The biofilter as shown in **Figure 25** will be placed around the drain run off, laydown area fence and around the construction site to reduce the transport of sediment from a construction site by providing a temporary physical barrier to sediment and reducing runoff velocities.

- **Street Sweeper**

Street Sweeper As shown in **Figure 25** will be going around the site during construction to free the area of dirt and debris.

5.5 Coordination requirements in order to perform work at Coronado NAB Pedestrian Tunnel

5.5.1 Personnel

The construction workers employed to carry out any activity on site are experienced and competently trained. All construction workers should have a clearance check prior to entering the NAB area and construction site.

During project inductions, all employees are thoroughly acquainted with the schedule and the contents of the Work Method Statement.

All vital records from site-specific orientations and training for any event are maintained by the construction project manager within the site administration offices at all times. Any relevant qualifications and training certificates of all employees are photocopied and kept in the project's personnel records file.

5.5.2 Risk Assessments

All personnel on site are made aware of the hazards and risks associated with the ongoing project at Coronado NAB Pedestrian Tunnel project. Prior to commencement of work, every worker is required to have sufficient knowledge of the necessary risk assessments for all materials, equipment, and works involved.

- Hazards to Identify
- Noise
- Dust
- Knockdown Hazard
- Body injury (especially foot, hand and head injury)
- Explosion
- Manual Handling

5.6 Construction Materials

1. Materials that will be used for the Coronado Pedestrian Tunnel will depend on the methods of geotechnical, design, and construction. In this project, there will be many materials for the construction process.

2. During the construction process, Taper Ties will be used to embed the concrete. Reinforcement Concrete is considered the most common modern lining material and the cost efficiency. Reinforcement Concrete can be used either by steel or fiber cement rain screens by sprayed on, prefabricated in panels, or casting in place. Rebars and Metal Studs Framing with Plaster will be used to make the pillars and walls stronger.
3. For the soil, Grout will be used to make the soil more stable and to fill the voids, since behind the tunnel It may contain various materials. The materials that it may have; silica fume, lime, sodium silicate, cement, and bentonite (which it considered a highly volcanic clay absorptive). During the construction, water will be used by a process called Low-Freezing gelatin explosive, this process will help to control the dust during drilling. Freezing Water and Liquid Nitrogen is a common process for the refrigerants to stabilize the soft ground.
4. Shield method will be used to prevent the collapse of the ground, this method used to construct the tunnel by the lining and excavation works as shown in **Figure 26**.

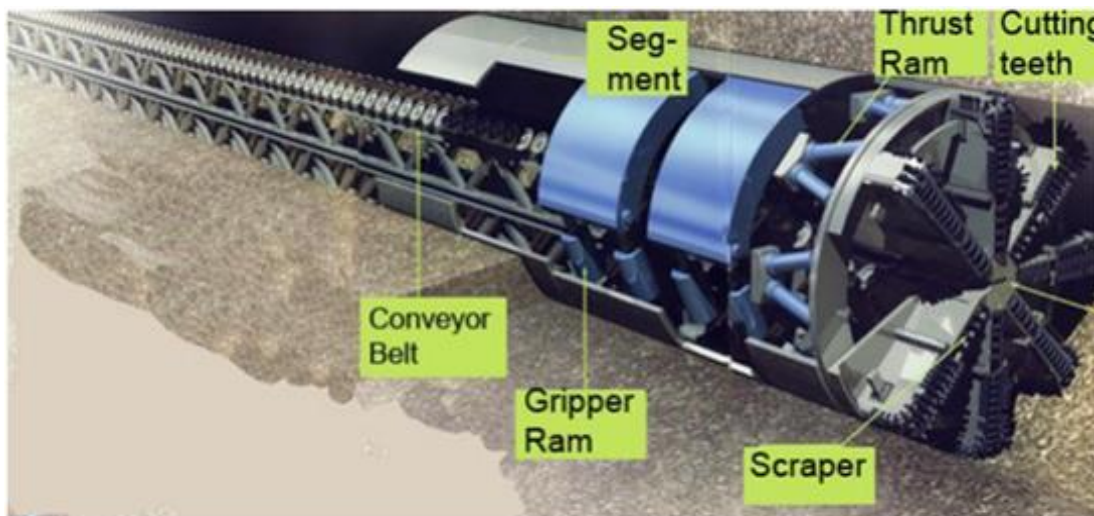

Main components of a shield machine

Figure 26: Components of Shield machine

The most important method that it will be used for this project is Mole or the Tunnel Boring Machine (TBM), this machine will be replaced by the Drill and Blast Method. This machine will

play an important role to excavate tunnels in a circular cross sectional through the soil and rock as shown in **Figure 27**.

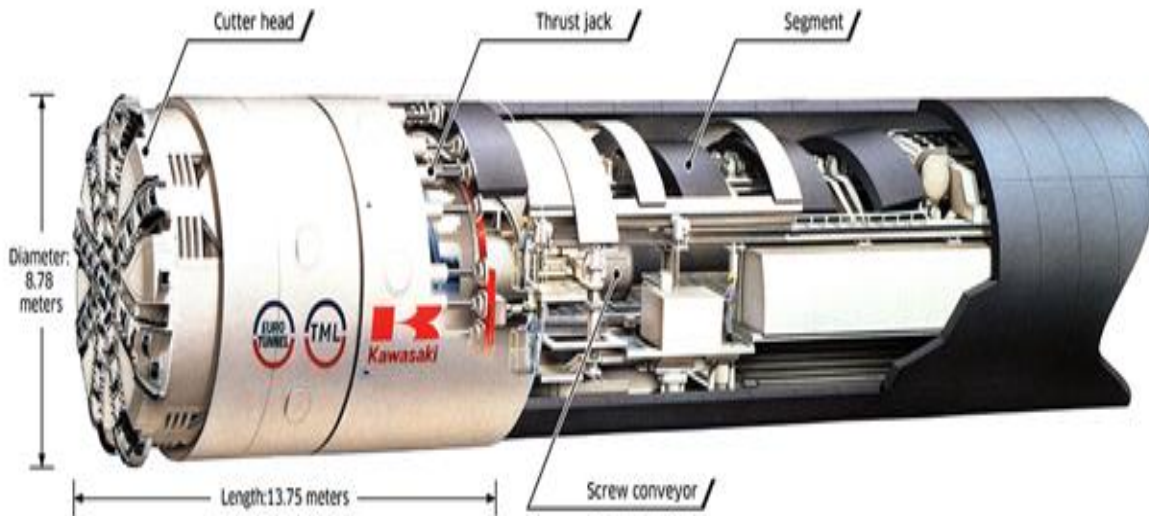

Figure 27: Tunnel Boring Machine

5.7 Construction Phasing

Scheduling → Establish Budget → Pre-Construction → Demolish → Earthwork → Structure → Interiors

Civil Creations Inc. will hire The Boring Company as an architect to work on schedule and develop activities and constraints by using Primavera P6. Civil Creations Inc. requires weekly meetings with subcontractors to increase certainty of schedule activities and schedule duration. Monthly updates will be sent to the owner for approval and review.

Subcontractors will meet with the Superintendent and Project Manager to brainstorm on the issues that will be very critical for the schedule.

There are several project's risks that Civil Creations Inc will face during the construction of the Coronado pedestrian tunnel. Potential project risks can result not only a delay of the duration of the project schedule, but also a danger to the workers on site and nearby pedestrians in the area.

By addressing these problems, Civil Creations Inc. will have to take note of the safety procedures during construction and staying on time for the completion date of the project.

5.7.1 Establish Budget

This project will eliminate an at grade crosswalk with an underground pedestrian tunnel. It's confirmed that many divisions will be involved such as: Preconstruction, Site Earthwork, Sub-Structure and Site Improvement. A budget and a financial plan have been set to provide a foundation for the delivery of services. It is estimated that the Preconstruction will shear a sum of \$342,535. Also, \$1,374,965 is provided to Site Earthwork Section. Sub-Structure estimated \$1,189,640 and last Site Improvement is \$231,250. Those estimations may vary depending on site and project conditions. Finally, the total cost estimate is \$3,138,390 as cost estimate details is provided in **Section 6**.

5.7.2 Preconstruction

Civil Creations Inc. will have a pull planning session for certain groups of trades for each phase of the project. All subcontractors will collaborate using backward pass to put activities into the process. Subcontractors will meet with the Superintendent and Project Manager to brainstorm on the issues that are very critical for the schedule and construction activities.

5.7.3 Demolish

On the east side of the tunnel, there are some bushes and trees that need to be relocated in order to build the stairs and the ramp of the tunnel. The size of some trees are 24" in diameter and 10' height. Bobcat e35i Mini Excavator would help in relocating and transplanting those trees in a location that suits their habitat along the SR75. However, the remaining bushes will be recycled instead of relocating them.

5.7.4 Earthwork

Earth work operation will include demolishing the trees and excavation. The trees are on the north east side of the Tunnel, as shown in **Figure 28**.

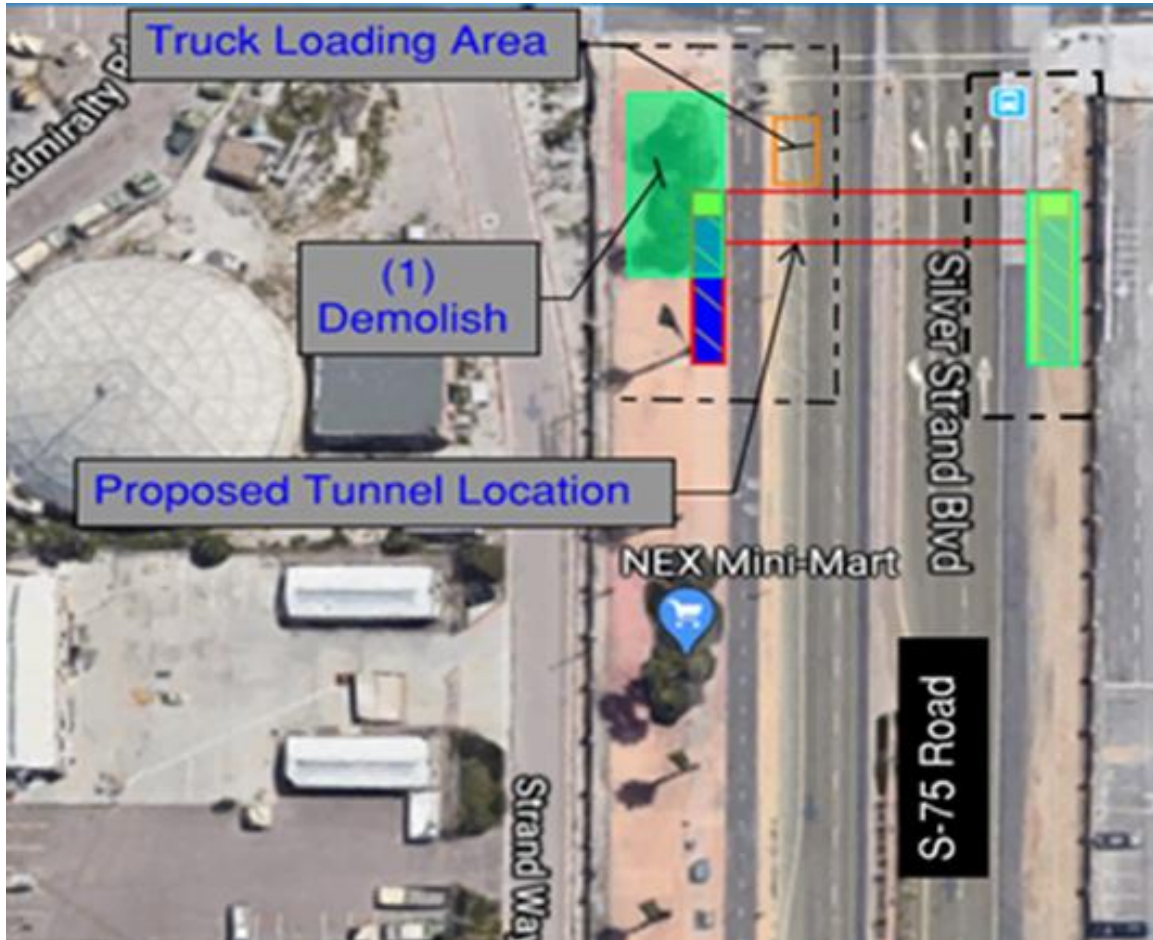

Figure 28: Demolish

Excavation works will be ongoing on the other side with the EC350E VOLVO excavator assisting in the ground digging to reach a target depth of 22 feet. There will be a truck haul cycle on going to load and dump the soil.

Boring machine will take place after reaching the depth of 22 feet. As shown in **Figure 29** the boring machine location.

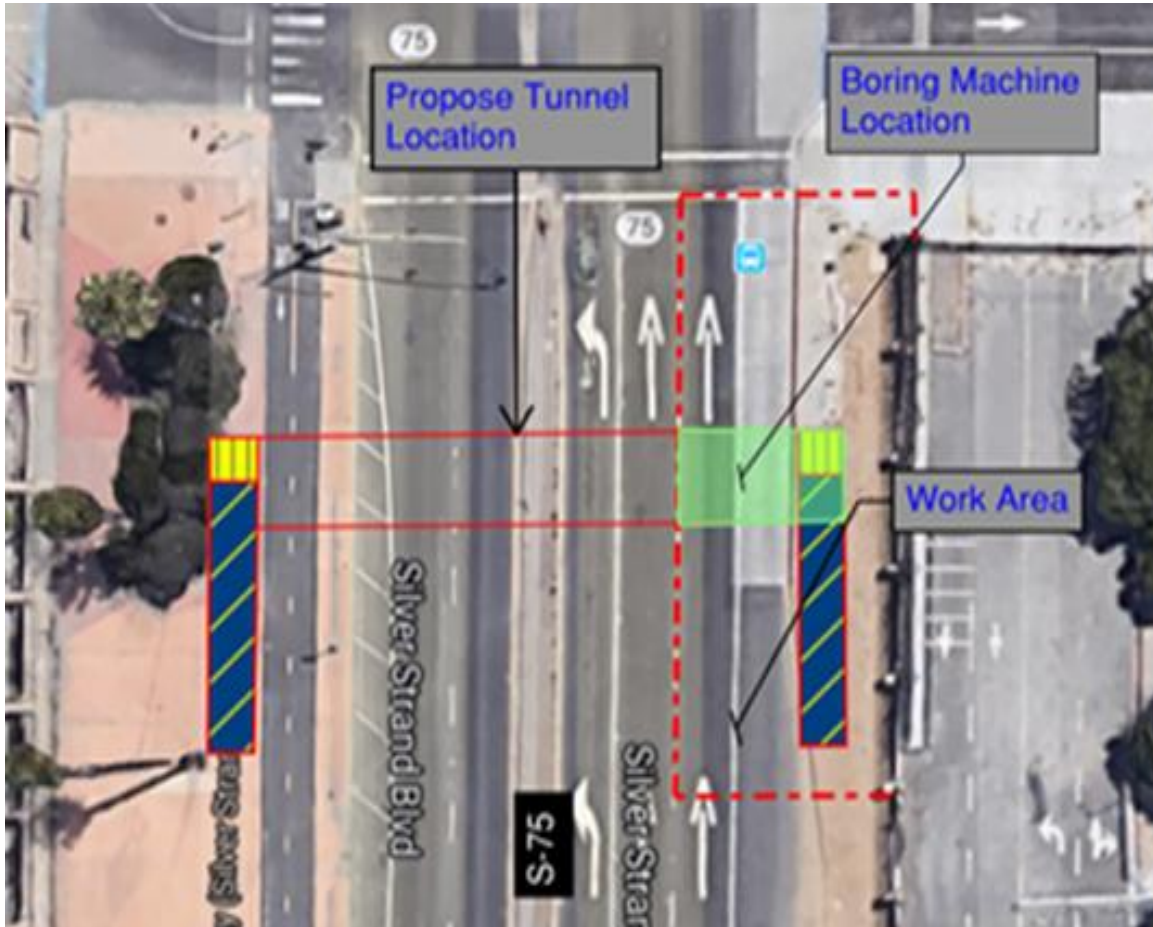

Figure 29: Boring Machine Location

Moving forward, there will be an excavation on the north side of the tunnel for a stairway and access ramp as shown in **Figure 30**. The project will have another truck cycle to load and dump the soil at the dump site.

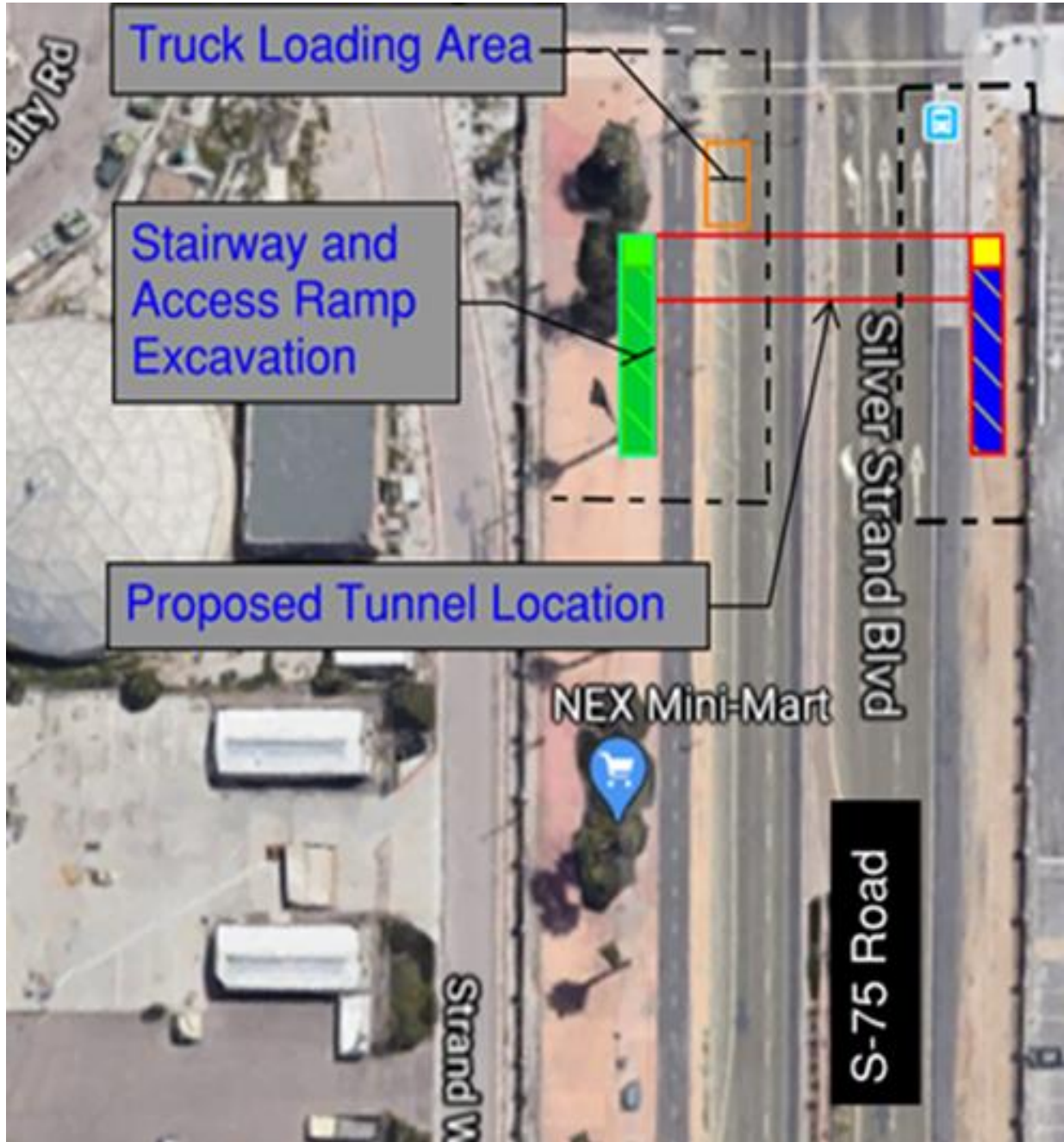

Figure 30: North Side Excavation

5.7.5 Structure

Due to the weak nature of the soil, shoring and strutted hot rolled sheet piles will be required to support the excavation. Strutted hot rolled sheet piles good for retaining soils and provides better water resistance. The interlocked sheet piles form a wall for permanent or temporary lateral earth support with reduced groundwater flow. First, sheet piles will be driven to the required depth (22 feet). Excavator digs a 5 feet bench around the area that it needs to be excavated. At 5 feet depth, installation of strut with waler and shoring will be required to prevent the soil from collapse.

The process will repeat continuously until the desired depth is achieved. In addition, strut spacing will take into consideration the size of the boring machine.

5.7.6 Interiors / Finishes

1. Flooring paving: Supply materials and execute paving tiles using cement mortar with (1:3) mix.
2. Cement plastering: Supply and execute cement plastering with (1:3) mix, for external concrete beams and walls.
3. Painting walls: supply materials and execute painting using oil paint for the walls.
4. False Ceiling: Supply materials & install False Ceiling (Plastic type) with 24X24inches for each panel.

5.7.7 Electrical Work

1. Install, and test main distribution board MDB comprising a wall mounted steel enclosure having the following details:
 - Ingress Protection: IP 54.
 - Dimensions: (32x24x12) inches, with lockable doors.
 - Paint: powder coating
 - Foamed-in door sealing gasket and lock.
 - The MDB enclosure shall consist of the followings:

- a) 1 No MCCB, 100A, 3phase 18Kiloampir
 - b) Set of copper bus-bar, 200A, 3 phase + Neutral + Earth
 - c) 2 No. MCCB, 80A, 3 phases
 - d) 3 No. Indicating lamps.
 - e) Approved brand Watt/Hour meter.
2. Install, and test 3 phase 18-way secondary distribution board SDB complete with 100A isolator, 3 phases, neutral and earth bus-bars and mcbs according to load distribution for the tunnel.
 3. Install and test (4x35mm²) PVC/PVC insulated stranded copper cable to connect the MDB to the electrical source. Using appropriate cable lugs, glands and put the cable into operation.
 4. Supply and test (4 x 16 mm² + E) PVC/ PVC insulated stranded copper cable. The cable shall be fixed on the walls to connect the MDB to the two SDBs using appropriate cable lugs, glands.
 5. Supply materials and wires install and test electrical wiring network to operate all electrical equipment including ventilation fans. The work includes extending the wiring inside UPVC pipes through the concrete roof, and on the walls, galvanized steel or plastic boxes, joints and switches.
 6. Install and test good quality waterproof LED lighting fixtures (ceiling mounted type with Projector shape) with 40 Watts, E27, and 12000K power saving bulbs.
 7. Install and test 40 Amp switched outlet for the ventilation and equipment.
 8. Install ventilation fan.



Cost Estimate



Coronado NAB Pedestrian Tunnel

Final Design Submittal by Civil Creations Inc.

Team 22

May 6th, 2020

Coronado NAB Pedestrian Tunnel								
Civil Creations Inc.								
		Cost Estimate						
DESCRIPTION	Unit	Quantity	Unit Price	Material Cost	Equipment Cost	Labor Cost	Total Cost	
SITE PREPARATION								
Permitting	LS	1	\$ 10,000.00	-	-	\$ 4,500.00	\$ 10,000.00	
Mobilization	LS	1	\$ 225,000.00	\$ 67,500.00	\$ 56,250.00	\$ 101,250.00	\$ 225,000.00	
DEMOLITION								
Palms	EA	2	\$ 2,900.00	\$ 1,740.00	\$ 1,450.00	\$ 2,610.00	\$ 5,800.00	
Bushes Trees	EA	9	\$ 1,100.00	\$ 2,970.00	\$ 2,475.00	\$ 4,455.00	\$ 9,900.00	
Bus Stop	EA	1	\$ 850.00	\$ 255.00	\$ 212.50	\$ 382.50	\$ 850.00	
AC Paving	SF	6550	\$ 13.50	\$ 26,527.50	\$ 22,106.25	\$ 39,791.25	\$ 88,425.00	
Storm Drains	LF	2	\$ 90.00	\$ 54.00	\$ 45.00	\$ 81.00	\$ 180.00	
Curb & Gutter	LF	280	\$ 8.50	\$ 714.00	\$ 595.00	\$ 1,071.00	\$ 2,380.00	
TOTAL SITE PREPARATION AND DEMOLITION							\$ 342,535.00	
SITE EARTHWORK								
Excavation Using Earth Pressure Balance Boring Machine	LS	1	\$ 1,200,000.00	\$ 360,000.00	\$ 300,000.00	\$ 540,000.00	\$ 1,200,000.00	
Import of Soils	CY	1400	\$ 40.00	\$ 16,800.00	\$ 14,000.00	\$ 25,200.00	\$ 56,000.00	
Export of Soils	CY	120	\$ 35.00	\$ 1,260.00	\$ 1,050.00	\$ 1,890.00	\$ 4,200.00	
Over-Excavation & Rock Removal	LS	1	\$ 50,000.00	\$ 15,000.00	\$ 12,500.00	\$ 22,500.00	\$ 50,000.00	
Paving Subgrade Preparation								
Sidewalk	SF	1750	\$ 3.00	\$ 1,575.00	\$ 1,312.50	\$ 2,362.50	\$ 5,250.00	
Hardscape Paving	SF	1400	\$ 3.00	\$ 1,260.00	\$ 1,050.00	\$ 1,890.00	\$ 4,200.00	
Fine Grading								
Sidewalk	SF	1750	\$ 2.50	\$ 1,312.50	\$ 1,093.75	\$ 1,968.75	\$ 4,375.00	
Hardscape Paving	SF	1400	\$ 2.50	\$ 1,050.00	\$ 875.00	\$ 1,575.00	\$ 3,500.00	
Erosion control	LS	1	\$ 22,000.00	\$ 6,600.00	\$ 5,500.00	\$ 9,900.00	\$ 22,000.00	
Sediment Control	LS	1	\$ 25,000.00	\$ 7,500.00	\$ 6,250.00	\$ 11,250.00	\$ 25,000.00	
Install Storm Drain Inlet Protection	LF	2	\$ 220.00	\$ 132.00	\$ 110.00	\$ 198.00	\$ 440.00	
TOTAL SITE EARTHWORK							\$ 1,374,965.00	
SUB-STRUCTURE								
Hot Rolled Sheet Piles	SF	943	\$ 900.00	\$ 254,610.00	\$ 212,175.00	\$ 381,915.00	\$ 848,700.00	
Strut	EA	30	\$ 60.00	\$ 540.00	\$ 450.00	\$ 810.00	\$ 1,800.00	
Waler	EA	24	\$ 60.00	\$ 432.00	\$ 360.00	\$ 648.00	\$ 1,440.00	
Soil Compaction	CY	75	\$ 37.00	\$ 832.50	\$ 693.75	\$ 1,248.75	\$ 2,775.00	
Grading	CY	75	\$ 28.00	\$ 630.00	\$ 525.00	\$ 945.00	\$ 2,100.00	
Ground Drainage System	LS	1	\$ 19,700.00	\$ 5,910.00	\$ 4,925.00	\$ 8,865.00	\$ 19,700.00	
Reconstruct Manholes Including Pipes	LS	1	\$ 1,125.00	\$ 337.50	\$ 281.25	\$ 506.25	\$ 1,125.00	
Reinforce Concrete Foundation	CY	94	\$ 670.00	\$ 18,894.00	\$ 15,745.00	\$ 28,341.00	\$ 62,980.00	
Reinforce Concrete for Floor Slab Including Rebars and Formwork	CY	102	\$ 670.00	\$ 20,502.00	\$ 17,085.00	\$ 30,753.00	\$ 68,340.00	
Reinforce Concrete for Roof Slab Including Rebars and Formwork	CY	102	\$ 700.00	\$ 21,420.00	\$ 17,850.00	\$ 32,130.00	\$ 71,400.00	
Reinforce Concrete for Stairs & Ramp Including Rebars and Formwork	CY	16	\$ 710.00	\$ 3,408.00	\$ 2,840.00	\$ 5,112.00	\$ 11,360.00	
Reinforce concrete for Wall System Including Rebars and Formwork	CY	144	\$ 680.00	\$ 29,376.00	\$ 24,480.00	\$ 44,064.00	\$ 97,920.00	
TOTAL SUB-STRUCTURE							\$ 1,189,640.00	
Site Improvement								
Reinforce Concrete for Sidewalks Including Rebars and Formwork	CY	50	\$ 670.00	\$ 10,050.00	\$ 8,375.00	\$ 15,075.00	\$ 33,500.00	
Curb & Gutter	LF	280	\$ 65.00	\$ 5,460.00	\$ 4,550.00	\$ 8,190.00	\$ 18,200.00	
AC Paving Including Base Material	SF	5600	\$ 30.00	\$ 50,400.00	\$ 42,000.00	\$ 75,600.00	\$ 168,000.00	
Palms Trees	EA	2	\$ 2,900.00	\$ 1,740.00	\$ 1,450.00	\$ 2,610.00	\$ 5,800.00	
Traffic Control Including Signs	LS	1	\$ 5,750.00	\$ 1,725.00	\$ 1,437.50	\$ 2,587.50	\$ 5,750.00	
TOTAL SITE IMPROVEMENT							\$ 231,250.00	
TOTAL PROJECT COST							\$ 3,138,390.00	



Project Schedule



Coronado NAB Pedestrian Tunnel

Final Design Submittal by Civil Creations Inc.

Team 22

May 6th, 2020

Coronado NAB Pedestrian Tunnel- Group #22

Civil Creations Inc. - Project Schedule

Activity ID	Activity Name	Original Duration	Remaining Duration	Start	Finish	2020			
						Feb	Mar	Apr	May
EC#1 Coronado NAB Pedestrian Tunnel		96	96	Feb-01-20	May-06-20	▼ M...			
EC#1.1 Proposal		15	15	Feb-01-20	Feb-15-20	▼ F...			
A1000	Project Approach	1	1	Feb-01-20*	Feb-01-20	P...			
A1010	Site Visit	1	1	Feb-03-20	Feb-03-20	S...			
A1020	Discipline Coordination	1	1	Feb-03-20	Feb-03-20	D...			
A1030	As-built research	7	7	Feb-04-20	Feb-10-20	A...			
A1040	Identify Scope of Work	6	6	Feb-05-20	Feb-10-20	r...			
A1050	Soil research	1	1	Feb-07-20	Feb-07-20	S...			
A1060	Study to identify development constraints	1	1	Feb-07-20	Feb-07-20	S...			
A1070	recommendations for the proposed pedestrian t	4	4	Feb-08-20	Feb-11-20	r...			
A1080	Create Preliminary Work Breakdown Structure	5	5	Feb-11-20	Feb-15-20	C...			
A1090	Create Preliminary Schedule	4	4	Feb-12-20	Feb-15-20	C...			
A1100	Create Responsibility Matrix	3	3	Feb-13-20	Feb-15-20	C...			
A1110	Resumes	1	1	Feb-13-20	Feb-13-20	R...			
A1120	Team partnering pledge	2	2	Feb-13-20	Feb-14-20	T...			
EC#1.2 50% Preliminary Design		35	35	Feb-15-20	Mar-20-20	▼ M...			
A1160	Soil Classification Study	4	4	Feb-15-20	Feb-18-20	S...			
A1170	Soil Layer Analysis	7	7	Feb-15-20	Feb-21-20	S...			
A1180	Soil mitigation	8	8	Feb-15-20	Feb-22-20	S...			
A1190	Research for Topography Plan	9	9	Feb-17-20	Feb-25-20	R...			
A1130	Site Visit	1	1	Feb-18-20*	Feb-18-20	S...			
A1140	General Reasearch	22	22	Feb-18-20	Mar-10-20	G...			
A1150	Create New Site layout	1	1	Feb-18-20	Feb-18-20	C...			
A1200	Create general site layout, extent of construction	11	11	Feb-18-20	Feb-28-20	C...			
A1210	Create Demolish plan	10	10	Feb-22-20	Mar-02-20	C...			
A1220	Identify BMPs for construction site	9	9	Feb-23-20	Mar-02-20	S...			
A1230	Structural system recommendations	6	6	Feb-25-20	Mar-01-20	S...			
A1250	Structural Calculations	13	13	Feb-25-20	Mar-08-20	S...			
A1240	Structural Analysis of Pedestrian Tunnel	10	10	Feb-27-20	Mar-07-20	S...			
A1260	Storm water analysis	12	12	Feb-28-20	Mar-10-20	S...			
A1270	Drainage System Study	12	12	Mar-01-20	Mar-12-20	D...			
A1280	Recommendations for Storm Watre Reuse and \	12	12	Mar-01-20	Mar-12-20	R...			
A1290	Create Profile Tunnel Plan	1	1	Mar-02-20	Mar-02-20	C...			
A1300	Determine Baseline material costs for future estim	11	11	Mar-03-20	Mar-13-20	D...			
A1310	Estimate Construction Costs	11	11	Mar-03-20	Mar-13-20	E...			
A1320	Traffic Control studies	6	6	Mar-05-20	Mar-10-20	T...			
A1330	Access plans/laydown	1	1	Mar-05-20	Mar-05-20	A...			
A1340	Site Logistics	6	6	Mar-05-20	Mar-12-20	S...			
A1350	Determine Construction Access	8	8	Mar-07-20	Mar-14-20	D...			
A1360	Construction Phasing	9	9	Mar-07-20	Mar-15-20	C...			
A1370	Analyze Construction Materials	9	9	Mar-08-20	Mar-16-20	A...			
A1380	Cost Estimating including Labors and Materials	9	9	Mar-09-20	Mar-17-20	C...			
A1390	Update WBS for weekly progress	9	9	Mar-10-20	Mar-18-20	U...			

█ Actual Work
 █ Critical Remaining Work
 ▼ Summary
█ Remaining Work
 ◆ Milestone

Feb-01-20 - May-06-20

Coronado NAB Pedestrian Tunnel- Group #22

Civil Creations Inc. - Project Schedule

Activity ID	Activity Name	Original Duration	Remaining Duration	Start	Finish	2020			
						Feb	Mar	Apr	May
A1400	Review Submittal	9	9	Mar-11-20	Mar-19-20				
A1410	50% CAD drawing completion	7	7	Mar-12-20	Mar-18-20				
A1420	Submit 50% Design	1	1	Mar-20-20	Mar-20-20				
EC#1.3	Final Design Submittal	45	45	Mar-23-20	May-06-20				
A1430	Soil bearing capacity	8	8	Mar-23-20*	Mar-30-20				
A1440	Development Constrains	8	8	Mar-25-20	Apr-01-20				
A1450	Finalize Cost Estimates	6	6	Mar-30-20	Apr-04-20				
A1460	Create Construction Schedule	7	7	Mar-31-20	Apr-06-20				
A1470	Development analysis	5	5	Apr-01-20	Apr-05-20				
A1480	Geotechnical Cost Estimates	7	7	Apr-01-20	Apr-07-20				
A1490	Finalize drainage study	17	17	Apr-04-20	Apr-20-20				
A1500	Finalize storm water analysis	15	15	Apr-04-20	Apr-18-20				
A1510	Finalize structural calculations	5	5	Apr-08-20	Apr-12-20				
A1520	Jack & Boring Pits with Shoring	15	15	Apr-08-20	Apr-22-20				
A1530	Headwall Location	15	15	Apr-08-20	Apr-22-20				
A1540	Finalize BMPs for construction site	7	7	Apr-11-20	Apr-17-20				
A1550	Review applicable codes and references	5	5	Apr-12-20	Apr-16-20				
A1560	Create Structural Engineering Plans	21	21	Apr-12-20	May-02-20				
A1570	Develop Site utilities plan	1	1	Apr-12-20	Apr-12-20				
A1580	Grading Plan	5	5	Apr-13-20	Apr-17-20				
A1620	Develop Public Improvement Plan	20	20	Apr-15-20	May-04-20				
A1590	Foundation Design	2	2	Apr-16-20	Apr-17-20				
A1600	Final Structural Design	2	2	Apr-16-20	Apr-17-20				
A1610	Design for shoring / Rebar	5	5	Apr-16-20	Apr-20-20				
A1630	Final Geotechnical Reports	18	18	Apr-17-20	May-04-20				
A1640	Final drainage plan	18	18	Apr-18-20	May-05-20				
A1650	Presentation Video	4	4	Apr-19-20	Apr-22-20				
A1660	Truck Haul	5	5	Apr-20-20	Apr-24-20				
A1670	Final Stormwater analysis	5	5	Apr-22-20	Apr-26-20				
A1680	100% CAD Drawing Completion	13	13	Apr-23-20	May-05-20				
A1690	Prepare powerpoint for presentation	5	5	May-01-20	May-05-20				
A1700	Final Design Day	1	1	May-06-20	May-06-20				

█ Actual Work
 █ Critical Remaining Work
 ▶ Summary
█ Remaining Work
 ◆ Milestone

Feb-01-20 - May-06-20

Page 2 of 2



Construction Schedule

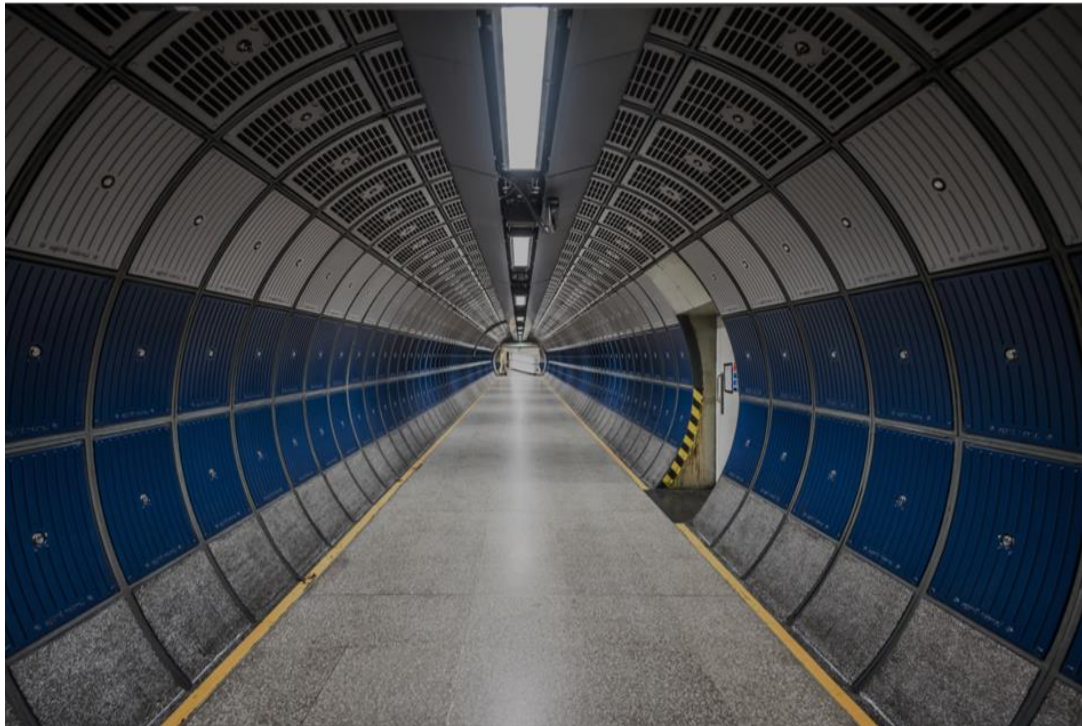

Coronado NAB Pedestrian Tunnel

Final Design Submittal by Civil Creations Inc.

Team 22

May 6th, 2020

Coronado NAB Pedestrian Tunnel- Group #22

Civil Creations Inc. - Construction Schedule

Activity ID	Activity Name	Original Duration	Remaining Duration	Start	Finish	2020												2021												2022												2023
						Jul	Aug	Sep	Oct	Nov	Dec	Jan	Feb	Mar	Apr	May	Jun	Jul	Aug	Sep	Oct	Nov	Dec	Jan	Feb	Mar	Apr	May	Jun	Jul	Aug	Sep	Oct	Nov	Dec	Jan						
EC Coronado NAB Pedestrian Tunnel																																										
EC.1 Pre construction																																										
A1000	Planning	7	7	Jul-06-20	Jul-14-20	P...																																				
A1010	Permitting	24	24	Jul-15-20	Aug-17-20	P...																																				
A1020	Determine Site Condition	2	2	Jul-21-20	Jul-22-20	D...																																				
A1030	Evaluating soil condition on site	3	3	Jul-23-20	Jul-27-20	E...																																				
A1040	Check Existing Utilities	2	2	Jul-28-20	Jul-29-20	C...																																				
A1050	Identifying Potential Issues & Outlining Solutions	5	5	Jul-30-20	Aug-05-20	I...																																				
A1060	Request for approval of materials	7	7	Aug-06-20	Aug-14-20	R...																																				
A1070	Determining Equipment Required	5	5	Aug-11-20	Aug-17-20	D...																																				
A1080	Delay of Materials - The Impact of Coronavirus	30	30	Aug-18-20	Sep-29-20	D...																																				
A1090	Establish Budget and Project Schedule	7	7	Sep-30-20	Oct-08-20	E...																																				
A1100	Site Plan Layout	1	1	Oct-09-20	Oct-09-20	S...																																				
A1110	Meetings with all Subcontractors	3	3	Oct-12-20	Oct-14-20	M...																																				
A1120	Prepare Site for Construction	1	1	Oct-15-20	Oct-15-20	P...																																				
EC.2 Site Mobilization																																										
A1130	Clean and Clear the site	2	2	Oct-16-20	Oct-19-20	N...																																				
A1140	Set Up Trailers	3	3	Oct-20-20	Oct-22-20	C...																																				
A1150	Fence Installation	1	1	Oct-23-20	Oct-23-20	S...																																				
A1160	Site Toilet Installation	1	1	Oct-26-20	Oct-26-20	F...																																				
A1170	Delivery of Machinery	4	4	Oct-27-20	Oct-30-20	S...																																				
A1180	Notification of NAB	1	1	Nov-02-20	Nov-02-20	D...																																				
EC.3 Storm Drain																																										
A1190	Erosion Control	2	2	Nov-03-20	Nov-04-20	N...																																				
A1200	Sediment Controls	2	2	Nov-05-20	Nov-06-20	E...																																				
A1210	Install Storm Drain Inlet Protection	1	1	Nov-09-20	Nov-09-20	S...																																				
A1220	Prepare the Site for Demolish & Excavation Work	1	1	Nov-10-20	Nov-10-20	I...																																				
EC.4 Demolition and Relocation																																										
A1230	Take off Palm Trees	3	3	Nov-12-20	Nov-16-20	P...																																				
A1240	Demolish All Bushes	2	2	Nov-19-20	Nov-20-20	D...																																				
A1250	AC paving	4	4	Nov-24-20	Nov-30-20	T...																																				
A1260	Storm drains	2	2	Nov-25-20	Nov-27-20	D...																																				
A1270	Curb & gutter	2	2	Nov-25-20	Nov-27-20	A...																																				
A1280	Replant Trees	3	3	Dec-01-20	Dec-03-20	S...																																				
A1290	Clean the Site	1	1	Dec-07-20	Dec-07-20	C...																																				
EC.5 Site Earthwork																																										
A1300	Site Preparation & Set Up	1	1	Dec-08-20	Dec-08-20	S...																																				
A1310	Set Up Signs for Traffic	1	1	Dec-09-20	Dec-09-20	S...																																				
A1320	Relocate Bus Stop	1	1	Dec-10-20	Dec-10-20	R...																																				
A1330	Staging West Site for Sheet Piling	7	7	Dec-11-20	Dec-21-20	S...																																				
A1340	West Side Excavation	45	45	Dec-22-20	Feb-25-21	W...																																				
A1350	Burying Anchors For Sheet Piles	6	6	Jan-29-21	Feb-05-21	B...																																				
A1360	Shoring & Installing Struts	20	20	Jan-29-21	Feb-25-21	S...																																				

█ Actual Work
 █ Critical Remaining Work
 Summary
█ Remaining Work
 ◆ Milestone

Jul-06-20 - Jan-16-23



Plans Set

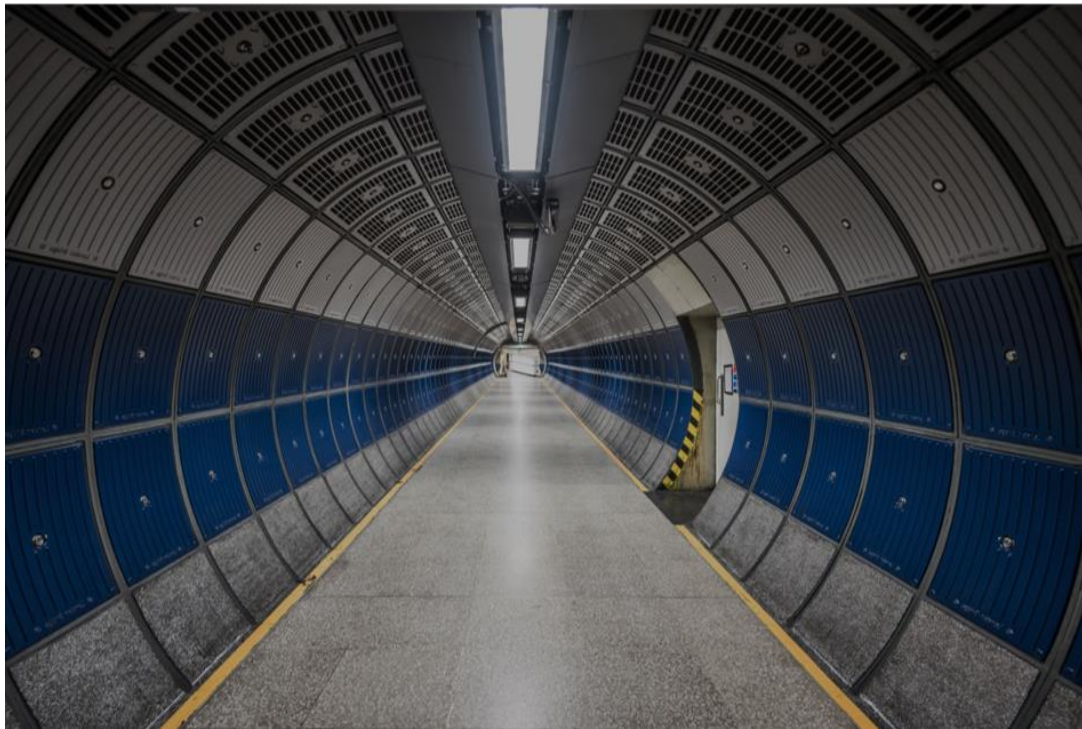

Coronado NAB Pedestrian Tunnel

Final Design Submittal by Civil Creations Inc.

Team 22

May 6th, 2020

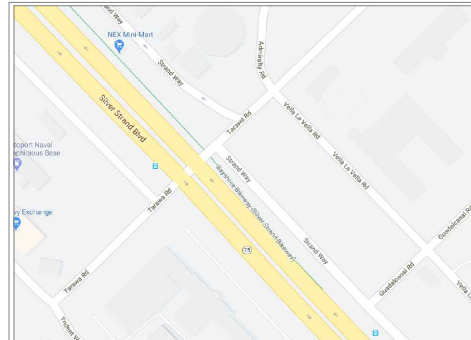

CORONADO NAB PEDESTRIAN TUNNEL

NOTES

CONTRACTOR/ BUILDER SHALL ESTABLISH PROPERTY LINES, SETBACKS AND EASEMENTS PRIOT TO START OF WORK.
CONTRACTOR SHALL FIELD VERIFY ALL EXCISING CONDITIONS PRIOR TO BID AND CONSTRUCTION.

ALL CONTRACTORS SHALL REPORT ANY CONFLICT- INCONSISTENCE IMMEDIATELY TO THE DESIGNER AND PRIOR

TO PROCEED WITH THEIR WORK.

DO NOT SCALE DRAWINGS, DIMENSIONS PREVAIL. THE DRAWINGS SHOW GENERAL INFORMATION ONLY. EXAMINE THE SITE TO DETERMINE THE EXCISING THE EXACT EXCISING CONDITIONS, CHARACTER AND EXTEND OF THE WORK TO BE PREFORMED AND OPERATIONS REQUIRED. VERIFY THE LOCATION OF EXCISING UTILITIES PRIOR TO DEFOLIATION AND START OF WORK. VERIFY EXCISING DIMENSIONS BEFORE PROCEEDING WITH THE WORK. OBTAIN FIELD MEASUREMENT FOR WORK REQUIRED TO BE ACCURATELY FITTED TO OTHER CONSTRUCTION. CONTRACTORS RESPONSIBLE FOR THE ACCURACY OF SUCH MEASUREMENTS AND PRECISE FITTING AND ASSEMBLY OF FINISHED WORK. VERIFY THAT ITEMS TO BE RECESSED OR SEMI-RECESSED IN EXISTING WALLS CAN BE INSTALLED PROPERLY ANY DISCREPANCIES PRIOR TO PROCEEDING WITH ANY WORK.PRIOR TO ORDERING



GENERAL REQUIREMENTS

"ALTERATIONS OR IMPROVEMENTS TO SINGLE FAMILY RESIDENCE REAL PROPERTY. AS OF JANUARY 1, 2014, SENATE BILL 407 REQUIRES A BUILDING PERMIT APPLICANT TO REPLACE ALL NONCOMPLIANT PLUMBING FIXTURES IN PROPERTIES BUILT AND AVAILABLE FOR USE ON OR BEFORE JANUARY 1, 1994 WITH WATER-CONSERVING WATER PLUMBING FIXTURES AS A CONDITION FOR APPROVAL OF A FINAL BUILDING PERMIT FOR BUILDING ALTERATIONS AND IMPROVEMENTS."

BUILDING MATERIALS WITH VISIBLE SIGNS OF WATER DAMAGE SHALL NOT BE INSTALLED. WALLS AND FRAMING SHALL NOT BE ENCLOSED WHEN THE FRAMING MEMBERS EXCEED 19 PERCENT MOISTURE CONTENT. INSULATION PRODUCTS THAT ARE VISIBLE WET OR HAVE HIGH MOISTURE CONTENT SHALL BE REPLACED OR ALLOWED TO DRY PRIOR TO ENCLOSURE IN WALL OR FLOOR CAVITIES. WET-APPLIED INSULATION SHALL FOLLOW THE MANUFACTURES DRYING RECOMMENDATIONS PRIOR TO ENCLOSURE.

RESIDENTIAL ADDITIONS AND ALTERATIONS SHALL REPLACE NONCOMPLIANT PLUMBING FIXTURES WITH WATER-CONSERVING PLUMBING FIXTURES.

"STATE SENATE BILL SB407 UPGRADE ALL EXISTING PLUMBING FIXTURES ." FOR MORE DETAILS PLEASE REFER TO THE STATE SENATE BILL SB407.

AS OF JANUARY 1, 2014, SENATE BILL 407 REQUIRES A BUILDING PERMIT APPLICANT TO REPLACE ALL NONCOMPLIANT PLUMBING FIXTURES IN PROPERTIES BUILT AND AVAILABLE FOR USE ON OR BEFORE JANUARY 1, 1994 WITH WATER-CONSERVING WATER PLUMBING FIXTURES AS A CONDITION FOR APPROVAL OF A FINAL BUILDING PERMIT FOR BUILDING ALTERATIONS AND IMPROVEMENTS."

JULY 1, 2014 ALL SMOKE ALARMS INCLUDING COMBINATION SMOKE ALARMS, THAT ARE SOLELY BATTERY POWERED SHALL CONTAIN A NON-REPLACEABLE, NON-REMOVABLE BATTERY THAT IS CAPABLE OF POWERING THE SMOKE ALARM FOR AT LEAST 10 YEARS. CARBON MONOXIDE DETECTORS SHALL BE COMPLIANT WITH UL 2075.

Project Data

PROJECT OF WORK PROPOSED
PEDESTRIAN TUNNEL



ADDRESS INTERSECTION OF
TARAWA RD AND SR-75

OWNER CITY OF CORONADO
1825 STRAND WAY
CORONADO, CA 92118

CONTRACTOR CIVIL CREATIONS INC.



SHEET INDEX

- A TITLE SHEET
- C-1 CIVIL SITE PLAN
- C-2 TUNNEL PROFILE AND FOUNDATION
- C-3 GRADING PLAN
- C-4 UTILITY PLAN
- C-5 EROSION CONTROL PLAN
- C-6 DEMOLISH PLAN
- C-7 STRUCTURAL PLAN
- C-8 TUNNEL SECTION AND DETAIL
- C-9 SLAB REINFORCEMENT PLAN
- C-10 TRAFFIC CONTROL PLAN

CORONADO NAB PEDESTRIAN TUNNEL		
CONSULTANT	CITY OF CORONADO, CALIFORNIA	SUBMITTED BY: MINA GHAREEB PROJECT MANAGER
		REVIEWED BY: AYA ALABOOSI PROJECT ENGINEER
	AUTOCAD LEAD BY: HANI NOORI PROJECT ENGINEER	DATE: 02-15-2020
		Scale: 1:8 SHEET NO. G-1

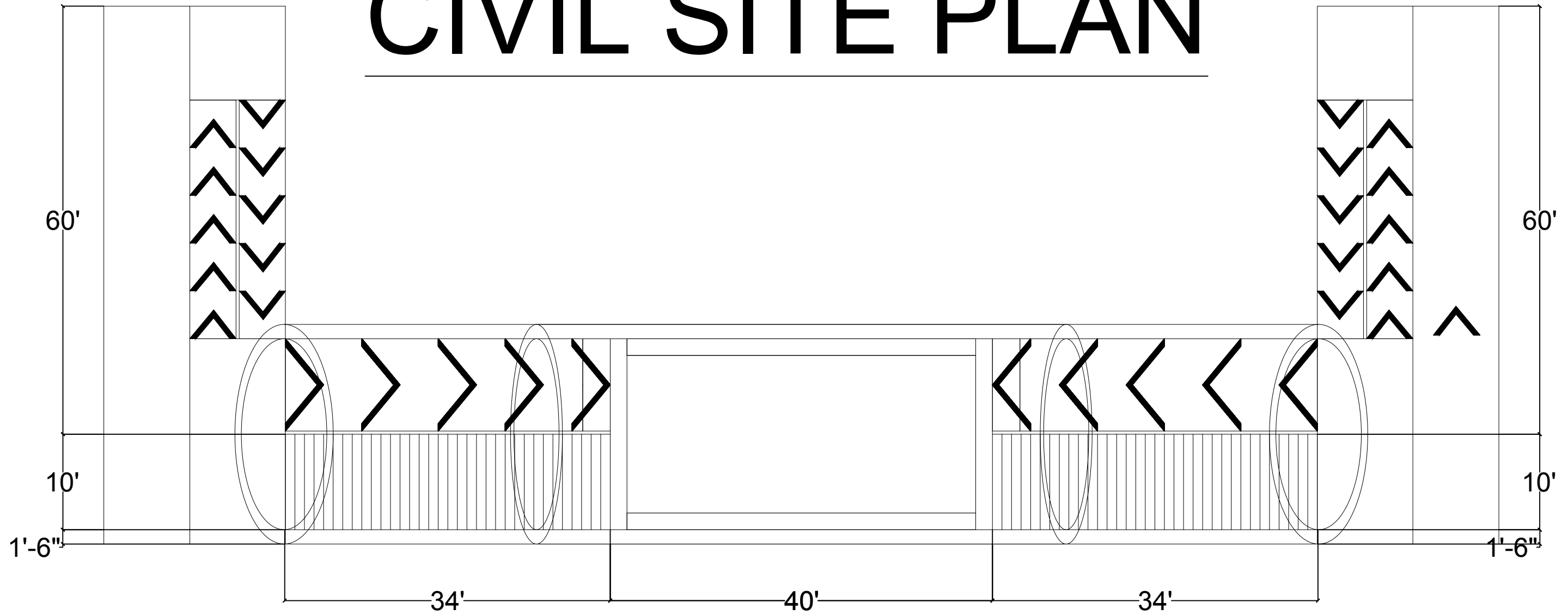
CIVIL SITE PLAN



CONSULTANT		CORONADO NAB PEDESTRIAN TUNNEL	
		CITY OF CORONADO, CALIFORNIA	SUBMITTED BY: Mina Ghareeb PROJECT MANAGER
		AUTOCAD LEAD BY: HANI NOORI PROJECT ENGINEER	REVIEWED BY: Mina Ghareeb PROJECT ENGINEER
		DATE: 04-14-2020	Scale: 1:8 SHEET NO. C-1

TUNNEL PROFILE & FOUNDATION

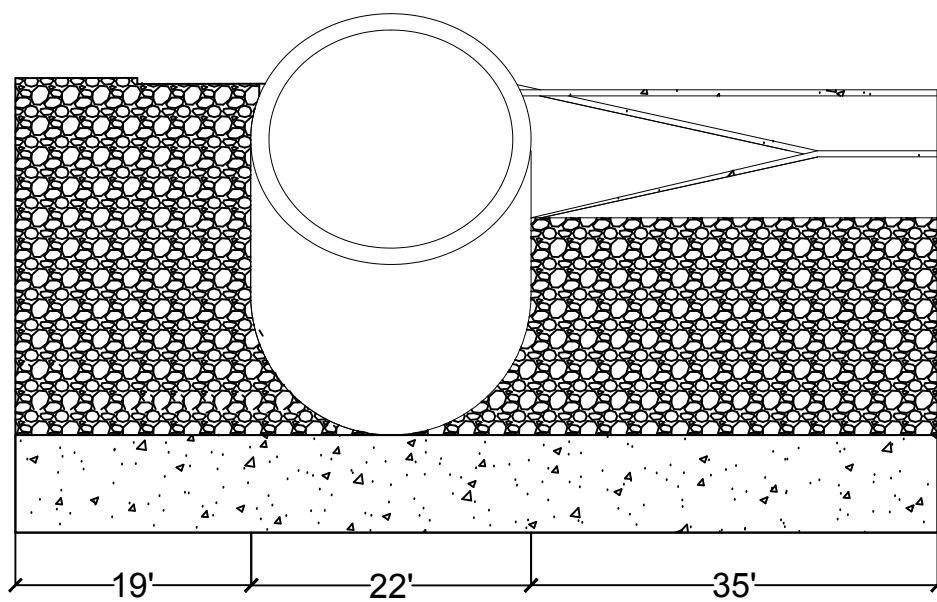
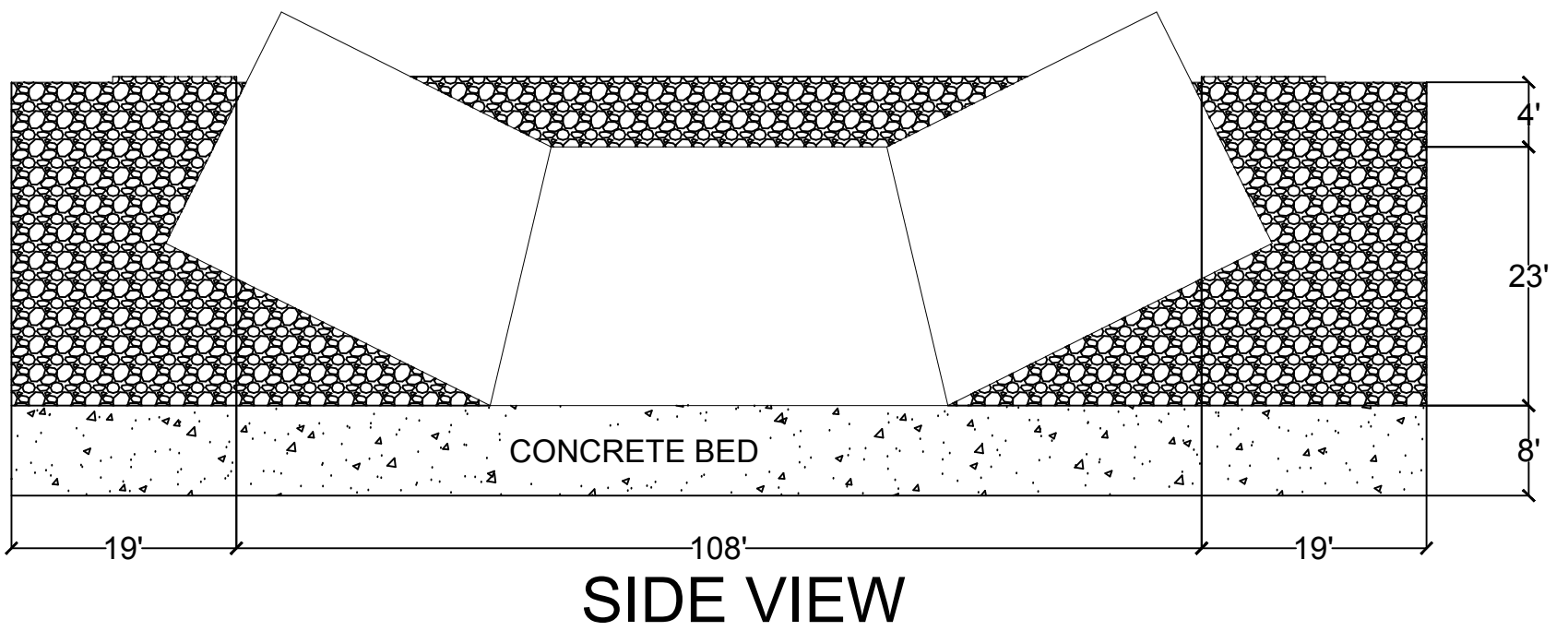
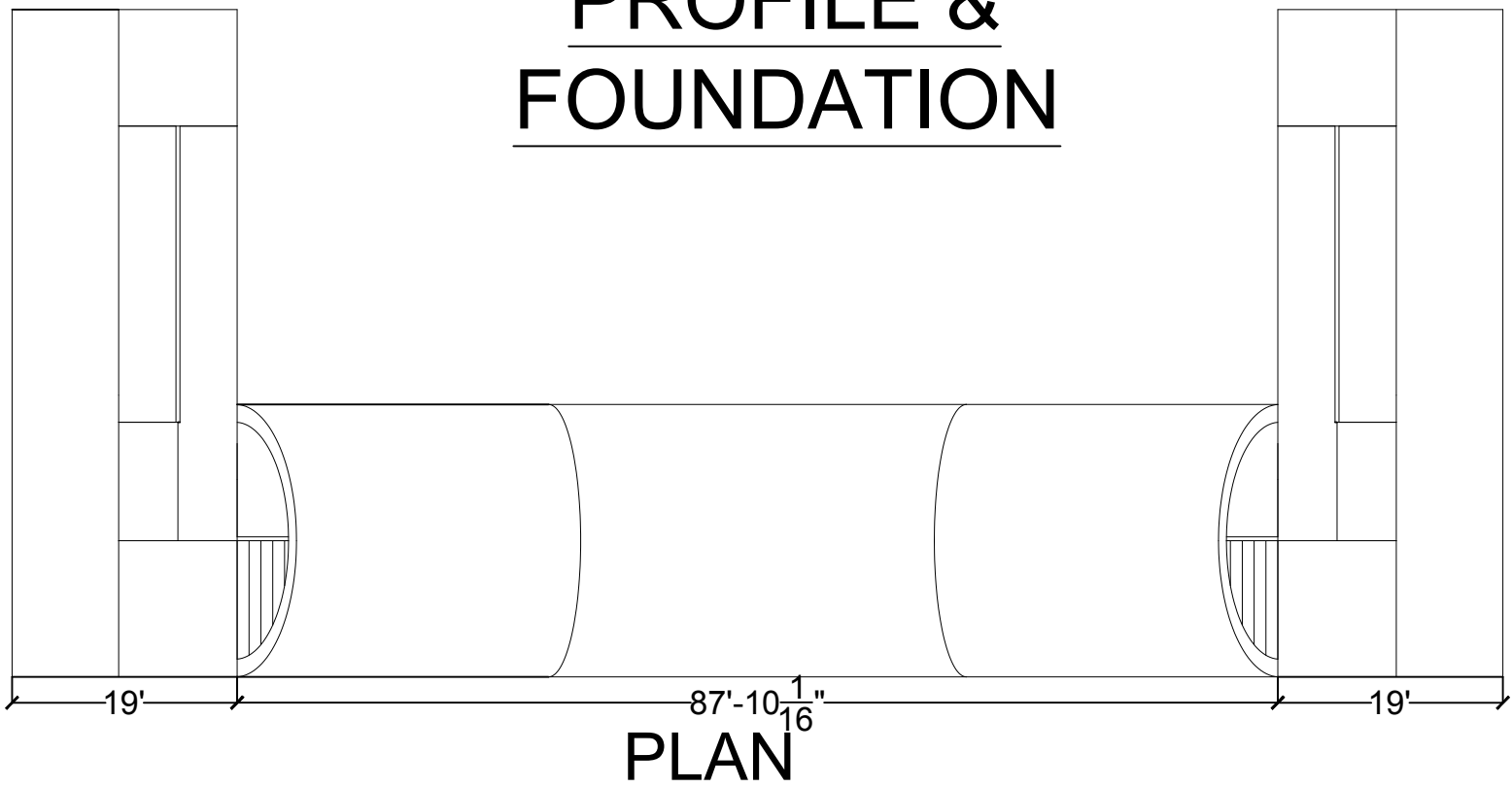





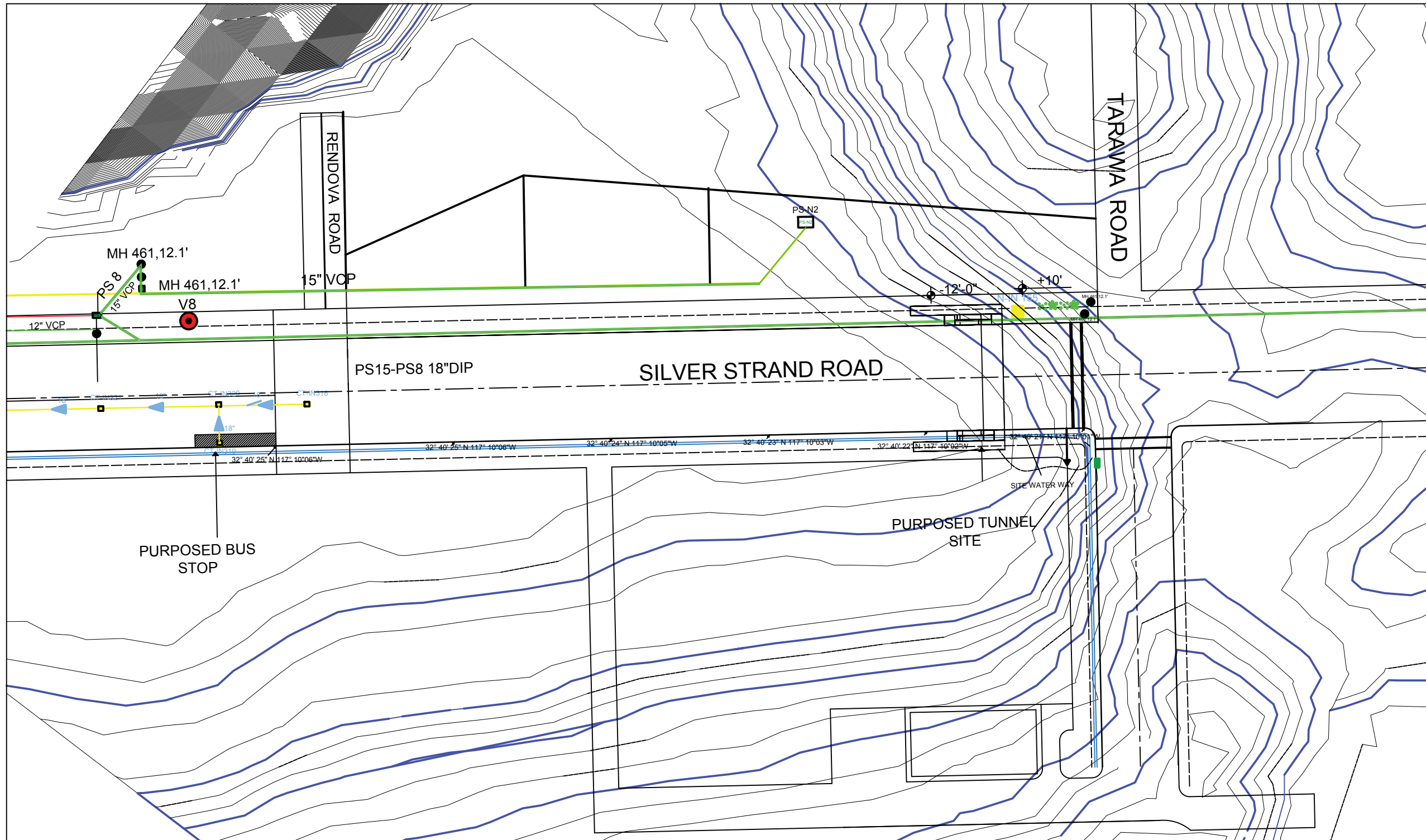

CORONADO NAB PEDESTRIAN TUNNEL		
CONSULTANT 	CITY OF CORONADO, CALIFORNIA	<small>SUBMITTED BY:</small> MINA GHAREEB <small>PROJECT MANAGER</small>
	<small>AUTOCAD LEAD BY:</small> HANI NOORI <small>PROJECT ENGINEER</small>	<small>REVIEWED BY:</small> AYA ALABOOSI <small>PROJECT ENGINEER</small>
<small>DATE:</small> 04-14-2020		<small>Scale:</small> 1:8 <small>SHEET NO.:</small> C-2

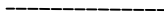
GRADING PLAN



LEGENDS

-  STORM WATER PIPE
-  8" DIA OR GREATER
-  CONTOUR LINE
-  SEWERAGE MANHOLE
-  STORM WATER MANHOLE
-  STORM WATER INLET (PRIVATE)
-  SEWER VENT
-  STORM GRAVITY MAIN (PRIVATE)

LEVELS BETWEEN CONTOURS IS 6"



CONSULTANT		CORONADO NAB PEDESTRIAN TUNNEL	
		CITY OF CORONADO, CALIFORNIA	PROJECT MANAGER
	AUTOCAD LEAD BY:	REVIEWED BY:	
	JARA AL ISOO	MUSTAFA RASHEED	
	PROJECT ENGINEER	PROJECT ENGINEER	
DATE:	04-22-2020	SCALE:	1:8
SHEET NO. C3			

UTILITY PLAN

CITY OF CORONADO
WASTE WATER & STORM WATER MAP
BOOK

WASTE WATER SYSTEM

- CLEAN WATER OUT
- SEWER DEAD END
- SEWER PUMP STATION
- SEWER PUMP STATION (PRIVATE)
- SEWER MANHOLE
- SEWER MANHOLE (PRIVATE)
- SEWER METERING STATION
- SEWER GRAVITY MAIN
- SEWER GRAVITY MAIN (AB)
- SEWER FORCE MAIN
- SEWER GRAVITY MAIN (PRIVATE)
- SEWER FORCE MAIN (PRIVATE)

STORM WATER SYSTEM

- STORM WATER HOLE
 - STORM WATER HOLE (PRIVATE)
 - STORM WATER INLET
 - STORM WATER INLET (ABANDONED)
 - STORM WATER INLET (PRIVATE)
 - STORM WATER OUTLET
 - STORM WATER OUTLET (PRIVATE)
 - SEWER VENT
 - STORM GRAVITY MAIN
 - STORM GRAVITY MAIN (AB)
 - STORM GRAVITY MAIN (PRIVATE)
 - STORM FORCE MAIN
 - STORM PUMP STATION
 - STORM DIVERTER
 - STORM DIVERTER
 - PARCEL BOUNDARY
- (AB) = ABANDONED
(PRIVATE) - SYSTEM ID
- CT - CAL TRANS HD - HOTEL DEL PT - PORT
L - LOEWS N - NAVY
SH - SHORES ST - STATE

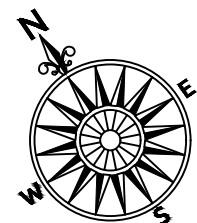
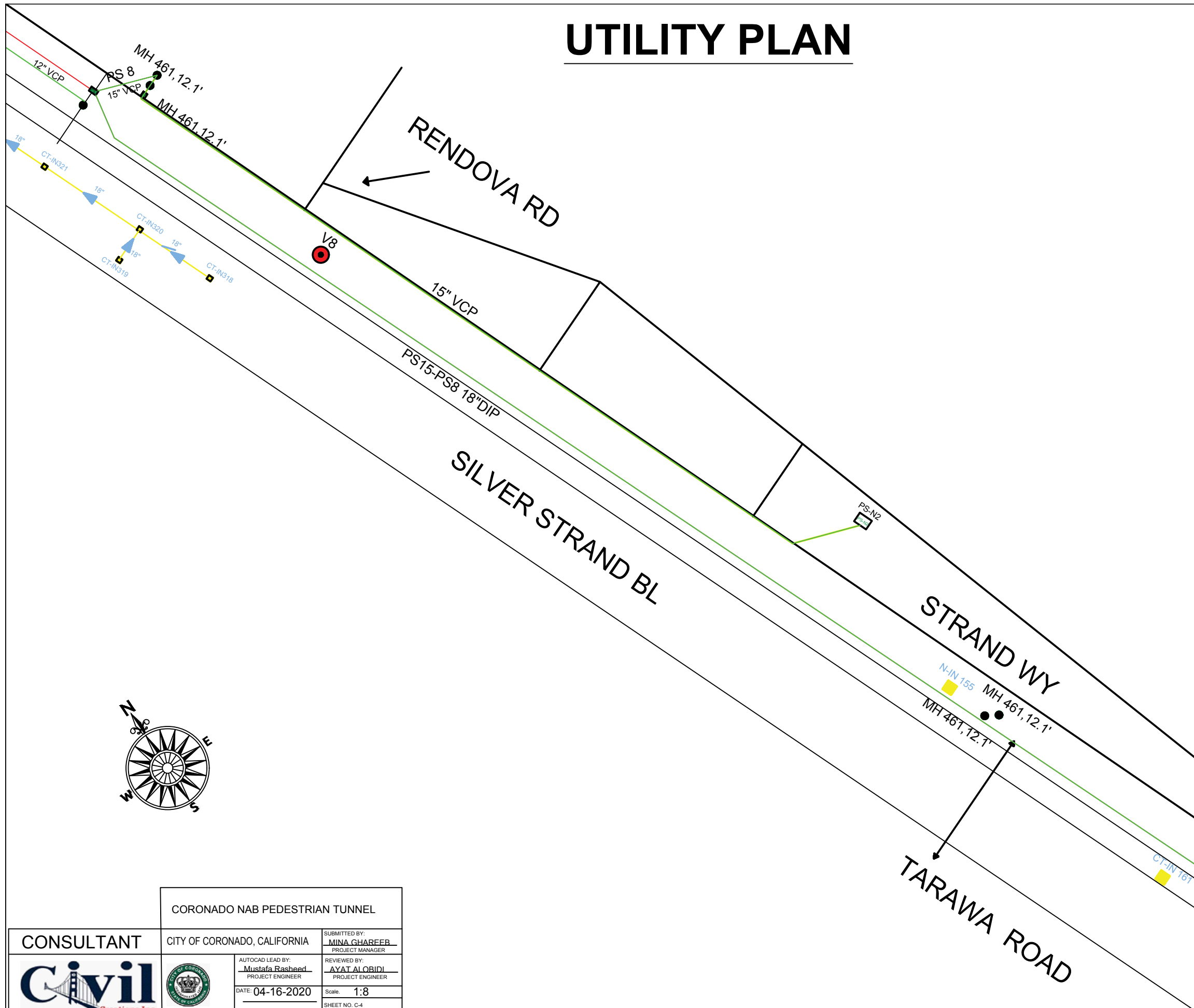





CORONADO NAB PEDESTRIAN TUNNEL

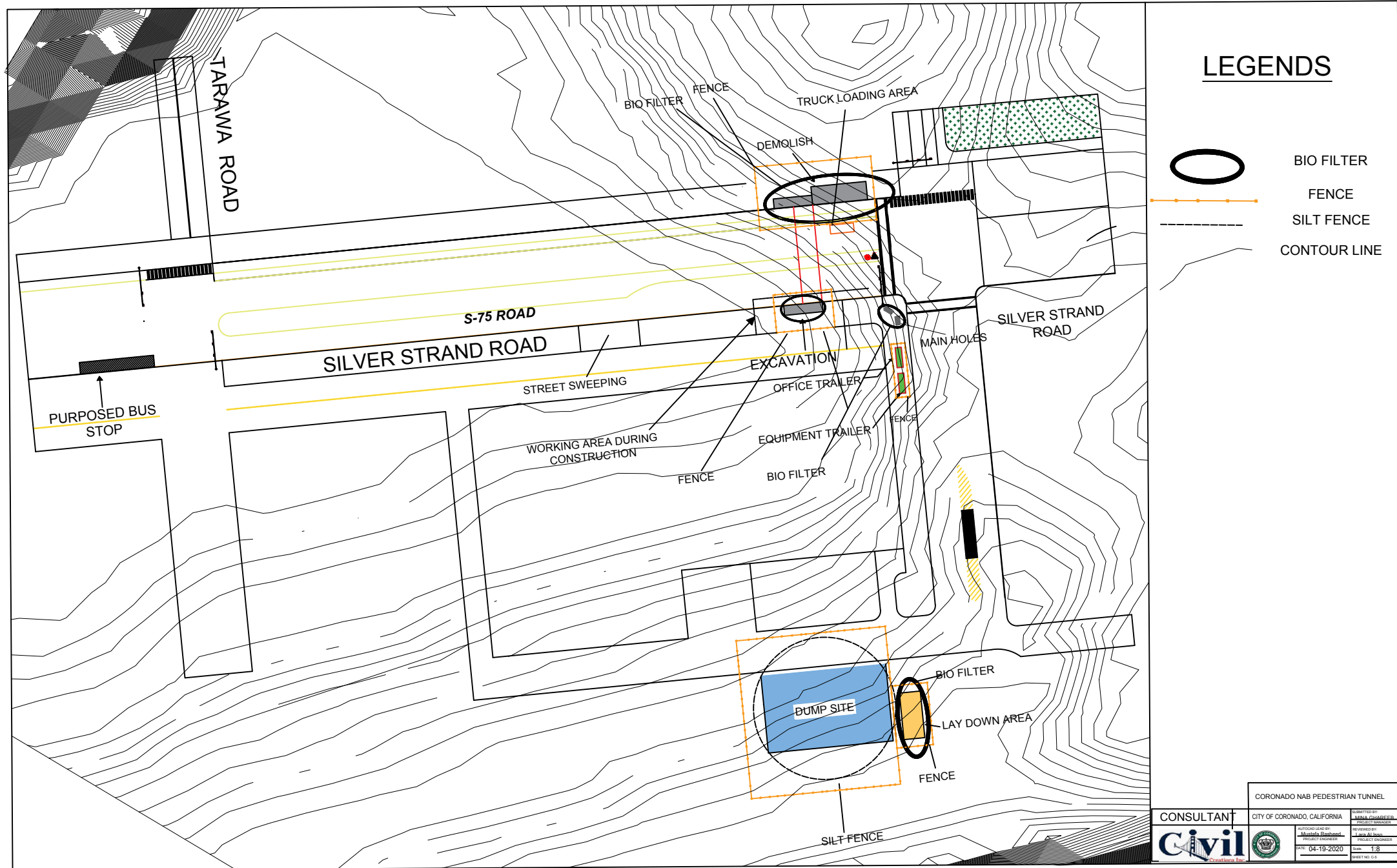

CONSULTANT 	CITY OF CORONADO, CALIFORNIA 	SUBMITTED BY: MINA GHAREEB PROJECT MANAGER
		AUTOCAD LEAD BY: Mustafa Rasheed PROJECT ENGINEER
		REVIEWED BY: AYAT ALOBIDI PROJECT ENGINEER
	DATE: 04-16-2020	Scale: 1:8
		SHEET NO. C-4

EROSION CONTROL PLAN





LEGENDS

-  BIO FILTER
-  FENCE
-  SILT FENCE
-  CONTOUR LINE

CORONADO NAB PEDESTRIAN TUNNEL	
CONSULTANT	CITY OF CORONADO, CALIFORNIA
	
04-19-2020	1/3

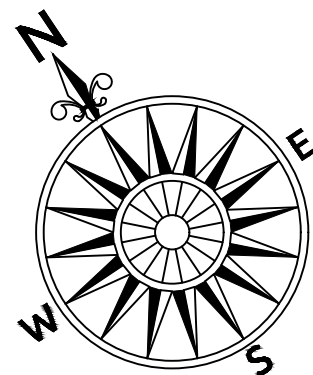
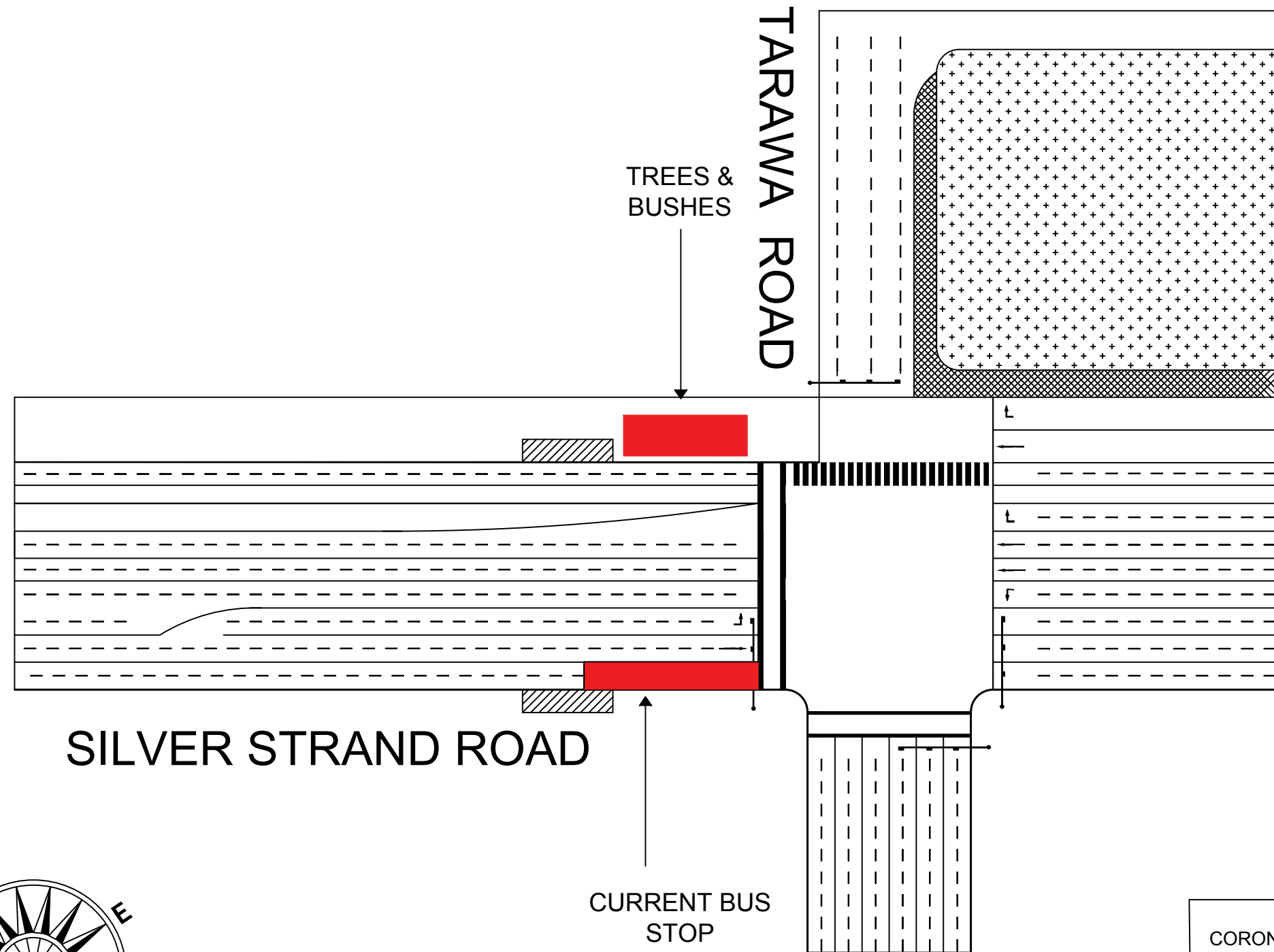
DEMOLISH PLAN



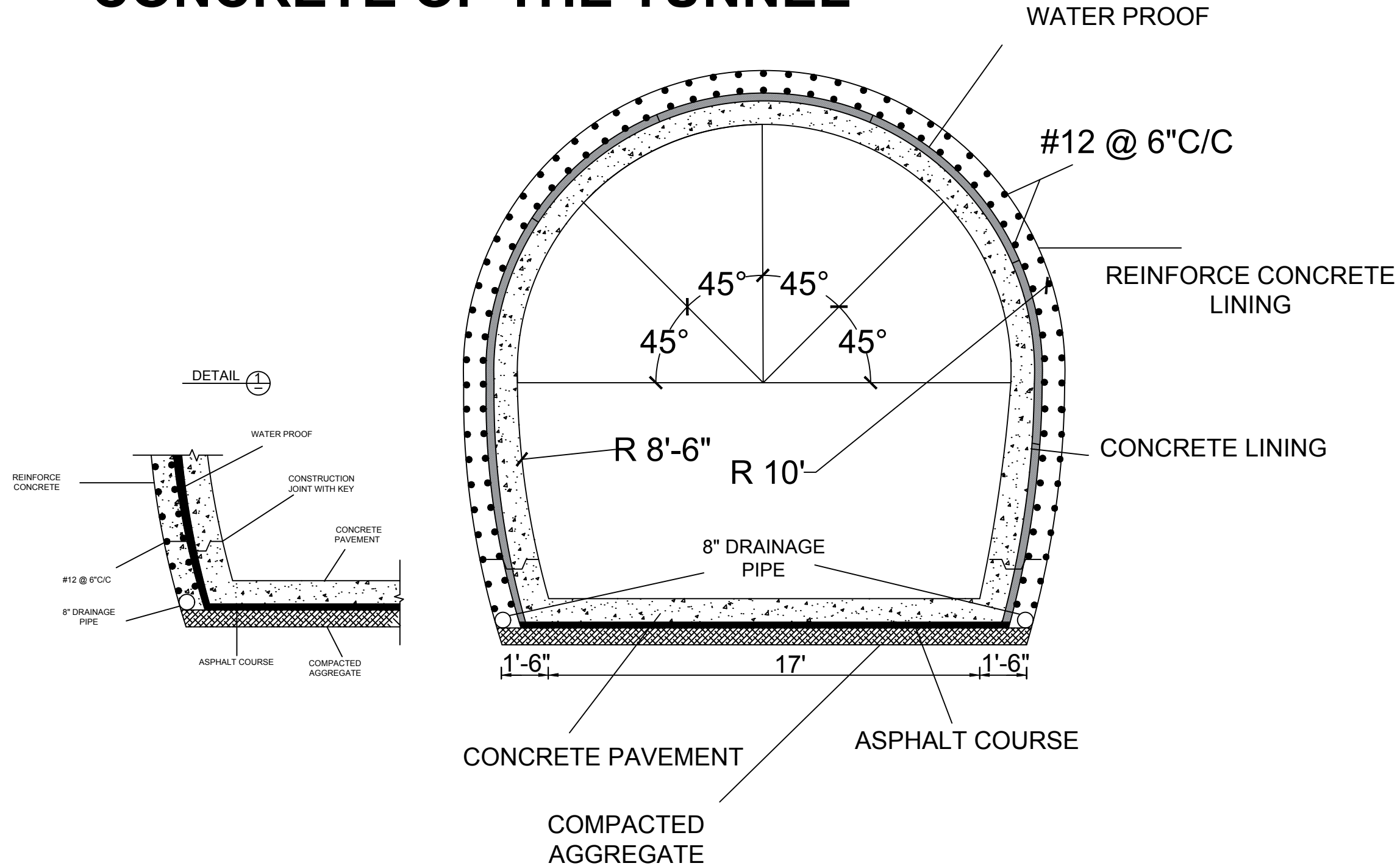

CONSULTANT		CORONADO NAB PEDESTRIAN TUNNEL	
		CITY OF CORONADO, CALIFORNIA	SUBMITTED BY: <u>MINA GHAREEB</u> PROJECT MANAGER
		AUTOCAD LEAD BY: <u>HANI NOORI</u> PROJECT ENGINEER	REVIEWED BY: <u>AYA ALBOQSI</u> PROJECT ENGINEER
		DATE: <u>04-14-2020</u>	Scale: 1:8 SHEET NO. C-6

STRUCTURAL PLAN AND REINFORCEMENT CONCRETE OF THE TUNNEL



MATERIAL SPECIFICATION & DRAWING DETAIL



- SPACING= 6"
- INNER RADIUS =8'-6"
- OUTER RADIUS =10'-0"
- SPACING OF REBAR
 $S= 0.60^2$
- CONCRETE $f'_c=4.01\text{ksi}$
- REINFORCING STEEL
 $f'_y=60.0\text{ksi}$, $E_s=2900$
- REINFORCING STEEL
 $f'_y=60.0\text{ksi}$, $E_s=2900$
- AREA OF SINGLE REBAR
 $A_{s\text{-bar}}=0.6\text{IN}^2$
- NORMAL WIGHT OF REINFORCEMENT
CONCRETE $W_c=0.150\text{kcf}$
- STRIP $W_{\text{strip}}=1\text{ft}$

CORONADO NAB PEDESTRIAN TUNNEL		
CONSULTANT	CITY OF CORONADO, CALIFORNIA	SUBMITTED BY: MINA GHAREEB PROJECT MANAGER
		AUTOCAD LEAD BY: MINA GHAREEB PROJECT ENGINEER
		REVIEWED BY: AYA AL ABOOSI PROJECT ENGINEER
	DATE: 04-18-2020	Scale: 1:8
		SHEET NO. C-7

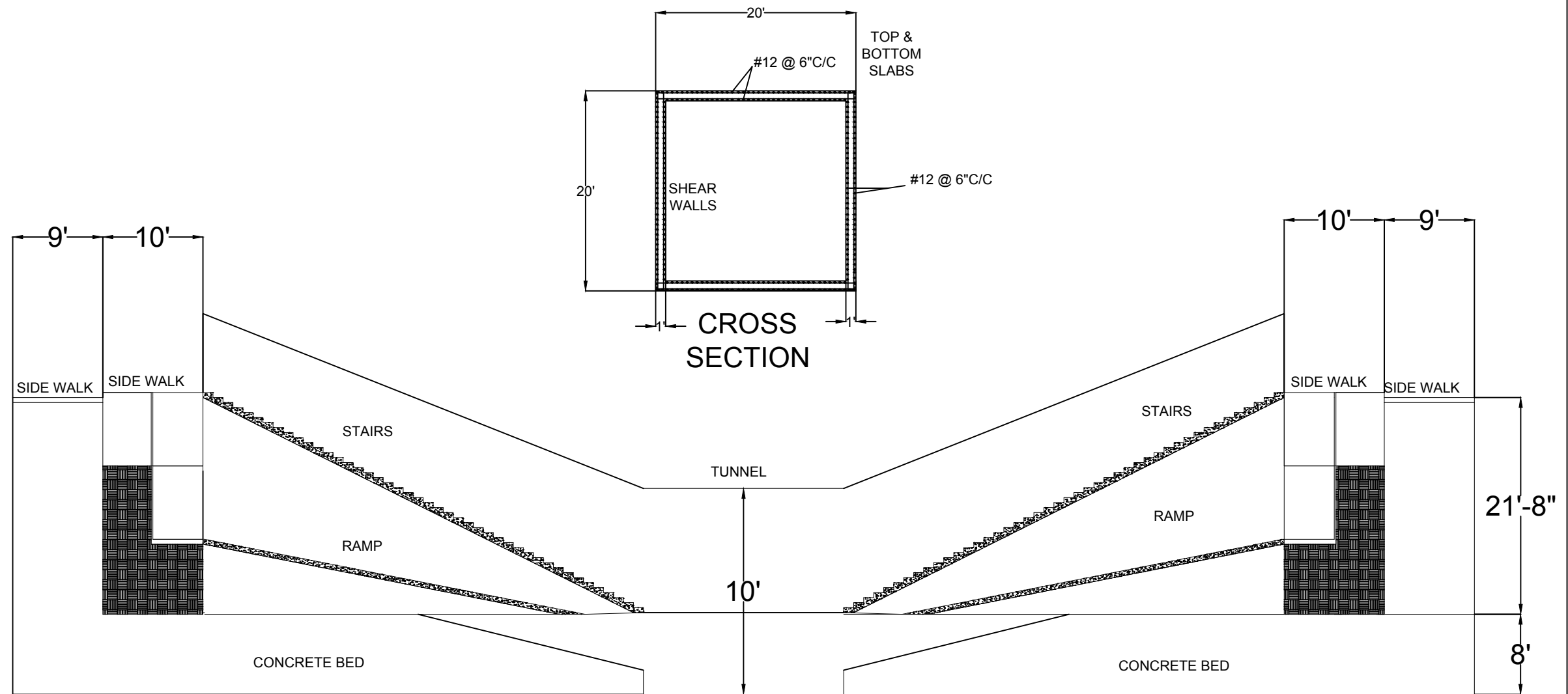
TUNNEL SECTION & DETAIL



SECTION

CORONADO NAB PEDESTRIAN TUNNEL			
CONSULTANT	CITY OF CORONADO, CALIFORNIA	SUBMITTED BY: MINA GHAREER PROJECT MANAGER	
		AUTOCAD LEAD BY: AYA AL ABOOSI PROJECT ENGINEER	REVIEWED BY: HANI NOORI PROJECT ENGINEER
		DATE: 04-18-2020	Scale: 1:8 SHEET NO. C-8

TRAFFIC CONTROL PLAN

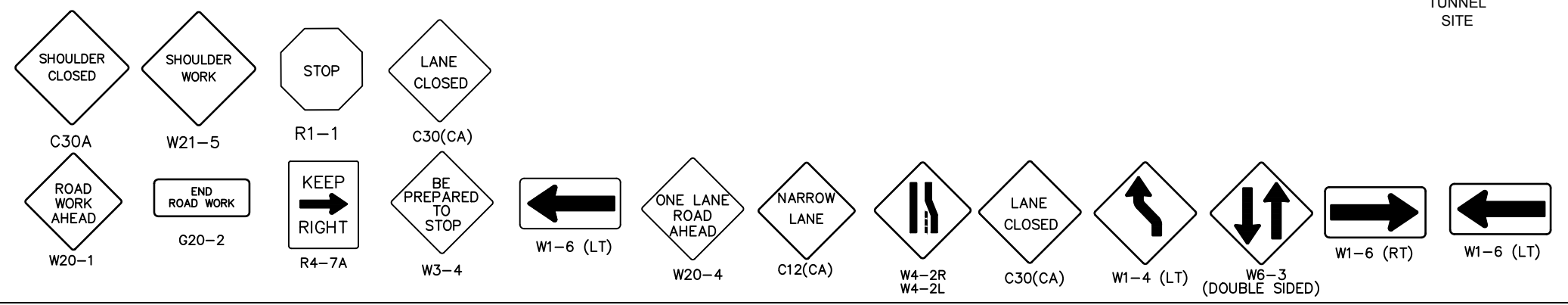
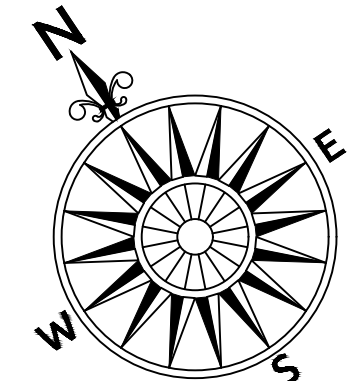
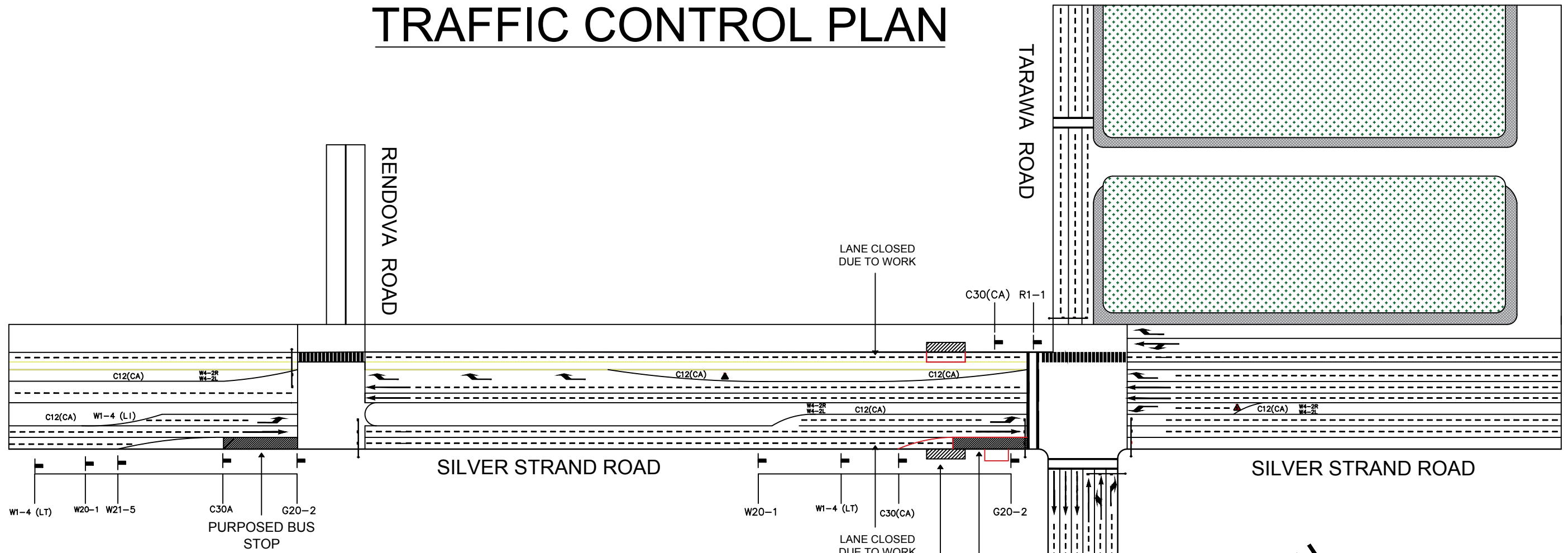

LEGEND



CORONADO NAB PEDESTRIAN TUNNEL		
CONSULTANT	CITY OF CORONADO, CALIFORNIA	SUBMITTED BY: MINA GHAREER PROJECT MANAGER
		AUTOCAD LEAD BY: AYAT ALOBIADI PROJECT ENGINEER
		REVIEWED BY: MINA GHAREER PROJECT ENGINEER
DATE: 04-14-2020	Scale: 1:8	SHEET NO. C-10